

L160/230 Series

HYUNDAI WIA CNC Turning Center



Technical Leader

L160/230 series, designed by Hyundai WIA with years of expertise and the latest technology, is a Turning Center that maximizes productivity and performance.



MODEL	Chuck Size				Bed		Turret
	6"	8"	10"	Sub 6"	Standard	Long	Turn Mill
L160A	•				•		
L160LA	•					•	
L160MA	•				•		•
L160LMA	•					•	•
L160LMSA	•			•		•	•
L230A		•			•		
L230LA		•				•	
L230MA		•			•		•
L230LMA		•				•	•
L230LMSA		•		•		•	•
L230C			•		•		
L230MC			•		•		•

Versatile, High Production CNC Turning Center

L160/L230 Series

- Shortened cycle times to improve productivity.
- Exceptionally engineered machine structure to produce various products.
- Angular ball bearing to maintain high rigidity
- Highly rigid structure designed through structural analysis
- Sub Spindle 6" chuck expands cutting capacity (Sub spindle models)
- BMT turret applied for heavy duty cutting (Mill turret models)



01

L160/L230

Basic Features

Main/Sub Spindle and Turret for High Productivity
Versatile CNC Turning Center

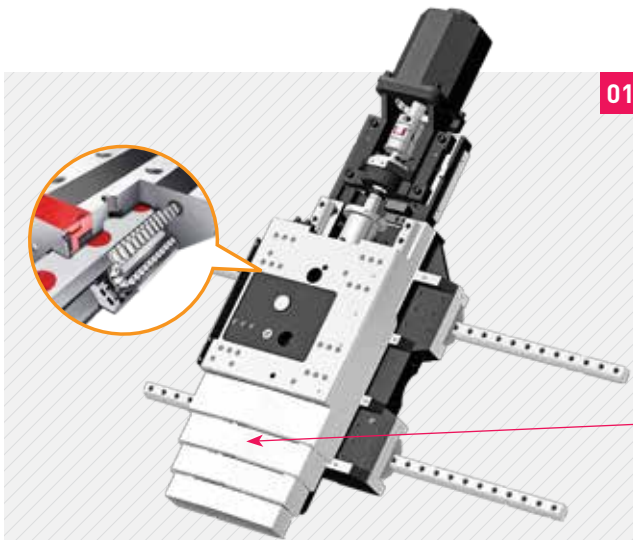

01

Guideway

L160/230 series applies roller type LM guideways in Z-axis delivering high rigidity and speed to improve productivity.

Ball Screw

Large diameter ball screws with preloading prevent deformation due to heat. Also double-anchor support method improves rigidity.

< Durability Improved by Application of **Multistage Slide Cover** >

Enlarging distance between each rail span

Previous Model (X-Axis) 200 mm(7.8")

L160/230 (X-Axis) 250 mm(10") **26% UP**

Previous Model (Z-Axis) 300 mm(11.8")

L160/230 (Z-Axis) 350 mm(13.7") **22% UP**

Main Spindle

Heat produced by the main spindle is blocked by applying a symmetric one-piece base and an insulation plate. This enables maintenance of high accuracy even during a long period of machining.

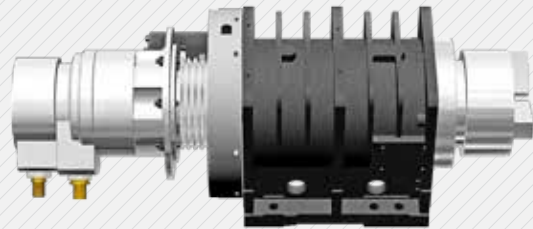

02

BMT Turret

The series is designed with a highly rigid BMT Turret where each holder is firmly fixed with 4 screws.

Therefore, it is possible to maintain accuracy in heavy duty machining operations.



03

6" Sub Spindle

Compared to the previous model, the sub spindle size is enlarged, improving process ability.



04

Basic Features

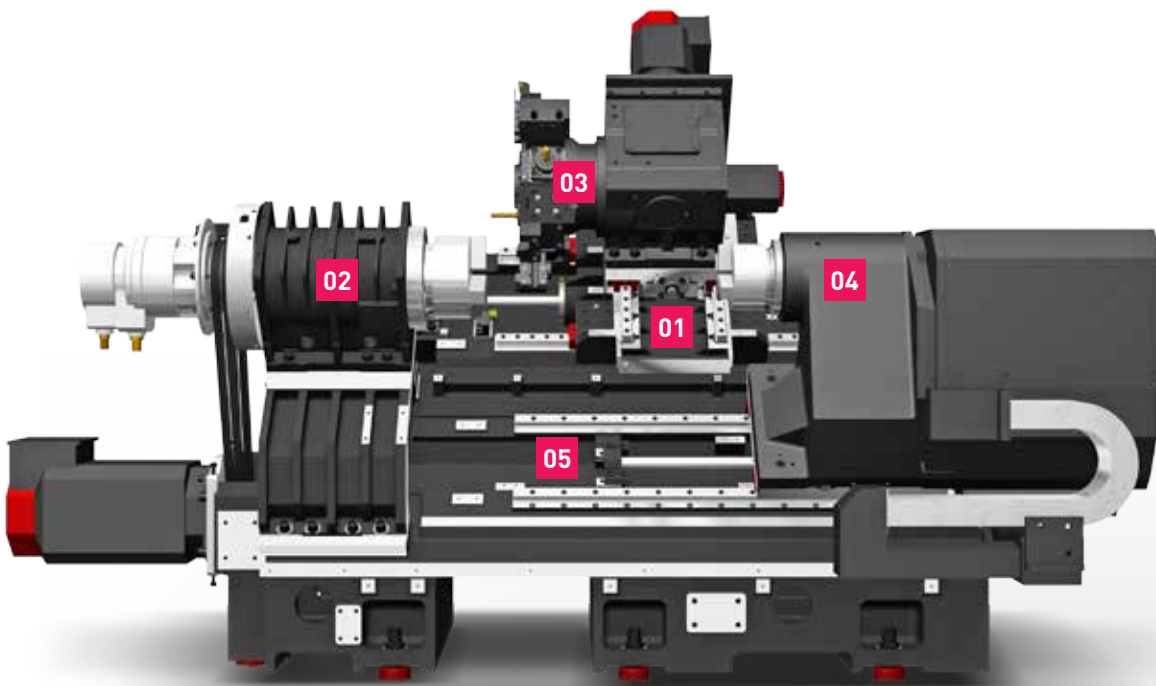

05 High Precision, High Rigidity All-In-One Type of Bed

45° slant bed is designed with square and tublar rib structure. It shows excellent performance in absorbing vibration and its high rigidity enables heavy duty cutting.

One-piece Coolant Tank

The coolant tank is changed from separate structure to one-piece structure to prevent overflow and clogging. It is possible to remove chips from right side of the machine which enhances chip removal capability.

⊙ Rigidity of the Bed Enhanced by **24%** through Structural Analysis

Reduction of non-cutting time

⊙ Rapid Traverse Rate (X/Z/ZB axis)

L160LMSA | L230LMSA : **36/36/30** m/min (**1,417/1,417/1,181** ipm)

⊙ Travel (X/Z/ZB axis)

L160A : **220/460** mm (**8.7"/18.1"**) L230A | L230C : **220/440** mm (**8.7"/17.3"**)

L160MA | L230MA/MC : **220/400** mm (**8.7"/15.7"**) L160LA/LMA | L230LA/LMA : **220/560** mm (**8.7"/22"**)

L160LMSA | L230LMSA : **220/560/590** mm (**8.7"/22"/23.2"**)

02
L160/L230

High Precision Spindle

Long Lasting High Accuracy & Excellent Performance
CNC Turning Center



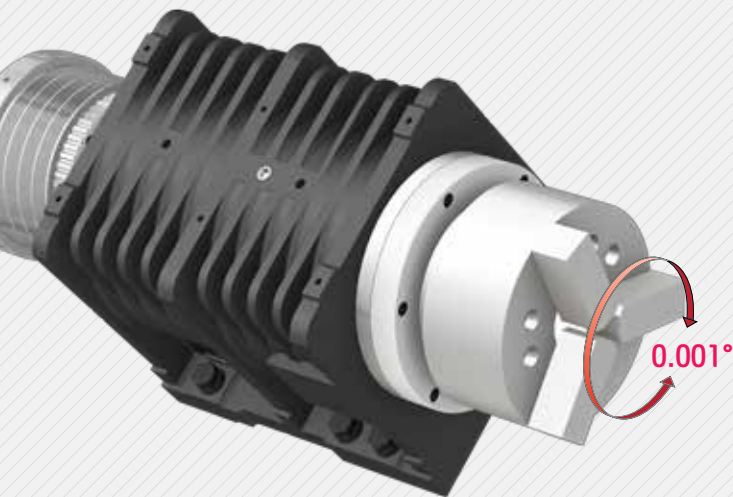

Main Spindle

The unit is able to maintain precision for a long time where the outer bearing part is assembled to the highest precision standards. Also, stable machining is possible by AC motor which controls the spindle at constant speed.

C-Axis Control

The C axis is capable of 0.001° control when milling turret is applied. Machining capability is strengthened with turning and milling operations.

Spindle Specifications [SIEMENS]

	Chuck Size	Max Sp. Speed	Bar Capacity	Output (30min.)
L160A Series	6"	6,000[6,000] rpm	Ø45 (Ø1.8")	11[10.8] kW (14.7[14.5] HP)
L230A Series	8"	4,000[4,000] rpm	Ø65 (Ø2.6")	15[22] kW (20.1[29.5] HP)
L230C Series	10"	3,000 rpm	Ø80 (Ø3.1")	18.5 kW (25 HP)

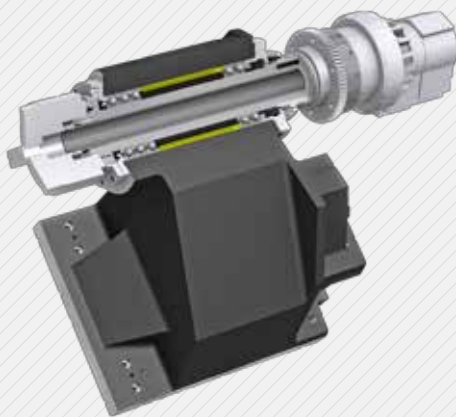

Chuck Size : 6" C-axis Indexing : 0.001°

Bar Capacity : Ø43 (Ø1.7")

Spindle Motor

Fanuc : 5.5/3.7 kW (7.4/5 HP)

Siemens : 5.9/4.9 kW (7.9/6.6 HP)

Sub Spindle

L160LMSA/L230LMSA applies 6" sub chuck with C-axis control of 0.001°.

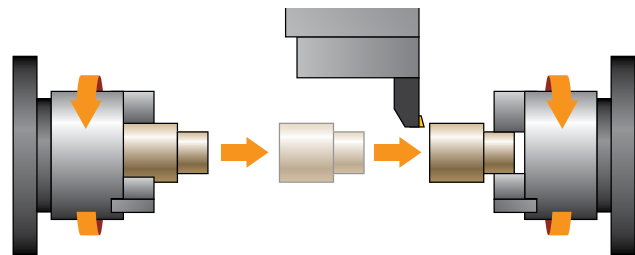

Machining with Sub Spindle

When the main spindle cutting is completed, the sub spindle rotation is synchronized with the main spindle allowing the workpiece to be transferred to the sub spindle, and machining can begin on the back side of the workpiece.



SIEMENS 1PH8 Spindle Motor

SIEMENS

The 1PH8 Series is a high quality performance motor providing concentricity of 10 μ m and fast response time. It operates smoothly in extreme environments such as high temperature, dust and dirt. The unique heat emission minimizing design makes it possible to maintain a high degree of accuracy at all times.

L160A Series Main Spindle

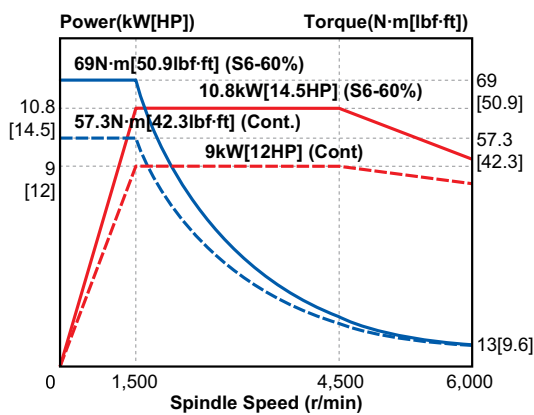

L230A Series Main Spindle

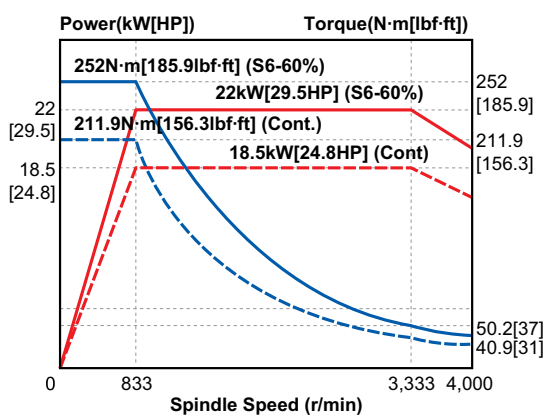

L160/230 Series Sub Spindle

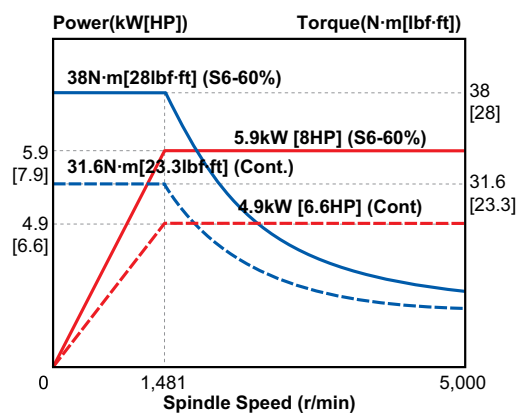

FANUC Spindle

L160A Series Main Spindle

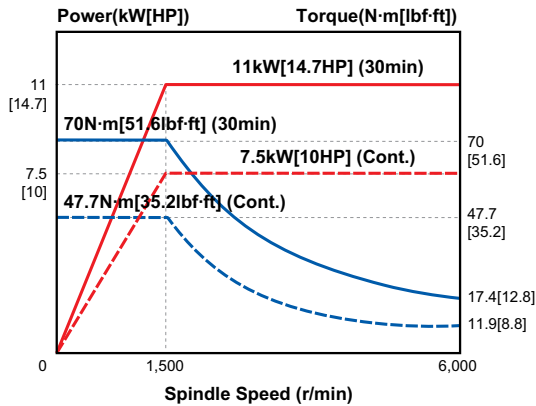

L230A Series Main Spindle

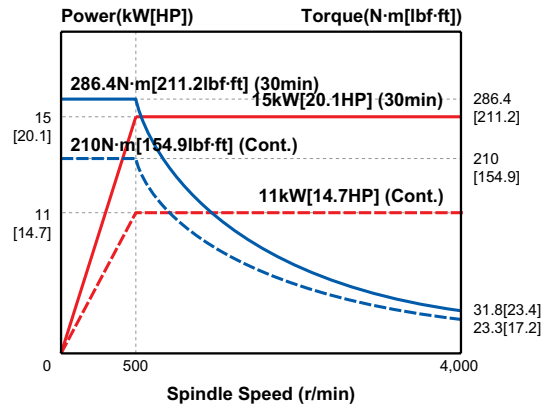

L230C Main Spindle

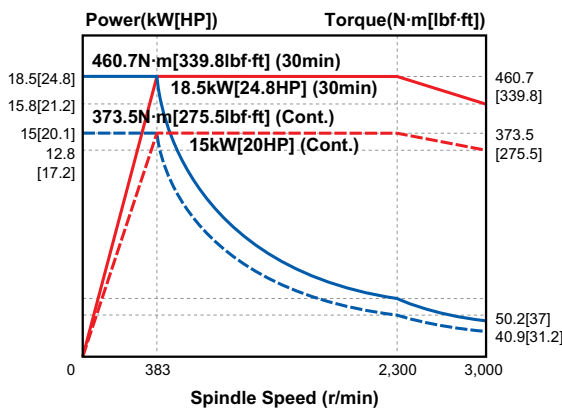

L160/230 Series Sub Spindle

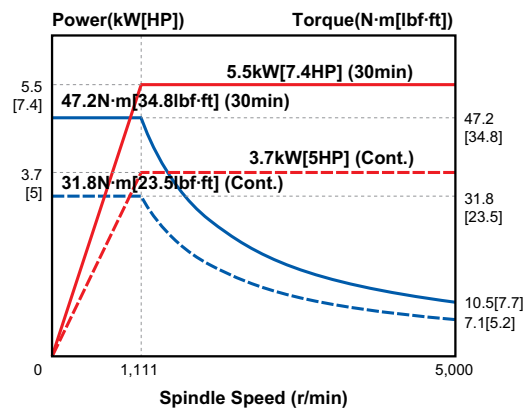

Tail Stock

One Touch Type



Quill Type



One Touch Type

Taper : MT#4

Stroke : 400 mm (15.7") {L Type : 600 mm (23.6")}

Quill Type **OPTION**

Taper : **MT#5**

Stroke : **300+100(Quill) mm**
(11.8"+3.9"[Quill])

N3

L160/L230

Servo Turret

High speed, High Accuracy, Highly Reliable
Servo Turret

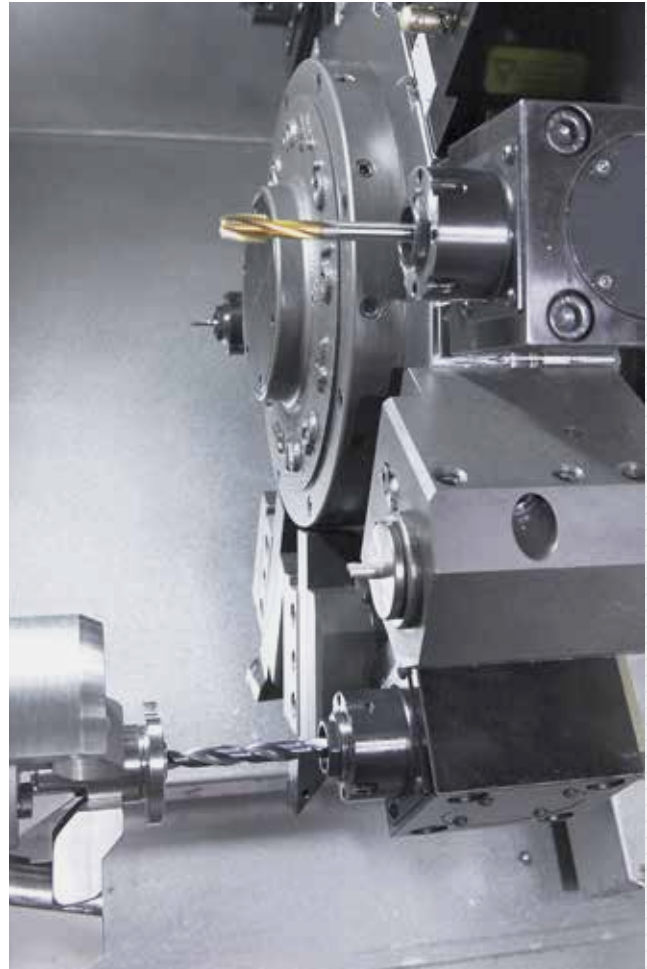

Turret

L160/230 Series has a high performance AC servo motor and 3-piece coupling attached which enhances its machining reliability. Powerful hydraulic tool clamping minimizes tool tip deviation due to load, which enhances heavy duty cutting ability.

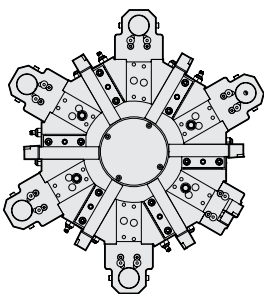

Servo Turret

- ◉ No. of Tools : 12 EA
- ◉ Tool Size (O.D/I.D)
□ 25/Ø40 (□ 1"/Ø1.6")
- ◉ Indexing Time :
0.2 sec/step
- ◉ Turret Clamp : 49 kN

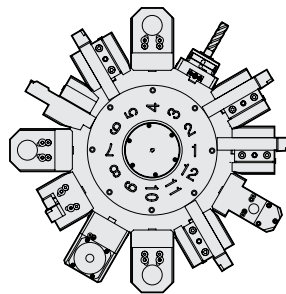

BMT55P Turret

- ◉ Speed : 5,000 [5,000] rpm
- ◉ Motor (Max./Cont.) :
3.7/2.2 [3.4/2.8] kW
(5/3 [4.6/3.8] HP)
- ◉ Torque (Max./Cont.)
23.5/14.2 [21.6/17.6] N·m
(17.3/10.5 [15.9/13] lbf·ft)

◆ [SIEMENS]

Mill Turret (BMT)

Strong clamping power is achieved by the 3-piece coupling. Also, two separate motors are used for indexing and tool rotation.

BMT turret where each holder is fixed with 4 screws, shows outstanding performance in milling, drilling and tapping during heavy duty cutting.

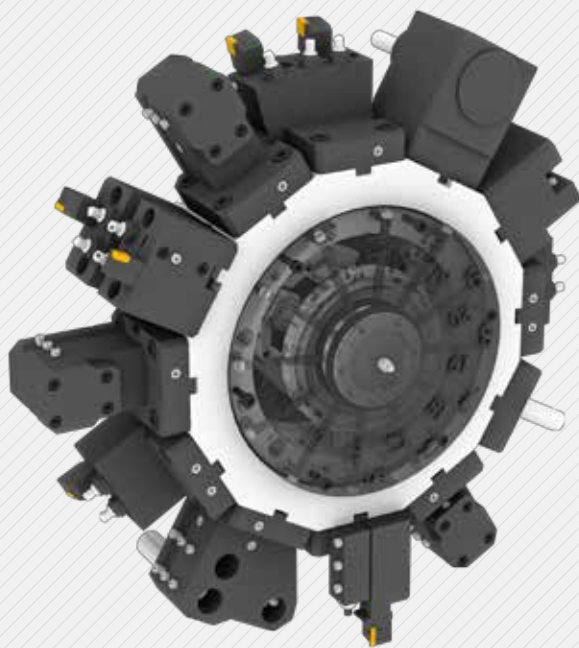

Mill Tool Holder

Machining capability is increased with the addition of a straight milling head which can remove material from the side of the workpiece, and an angular milling head which can perform I.D. operations.

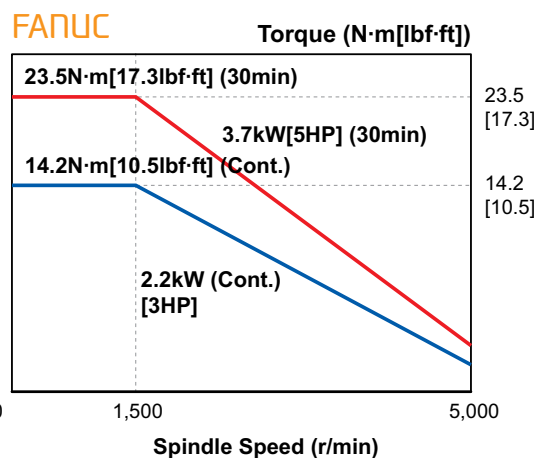
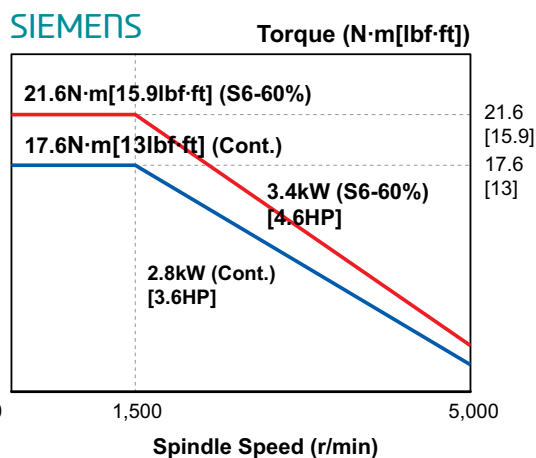
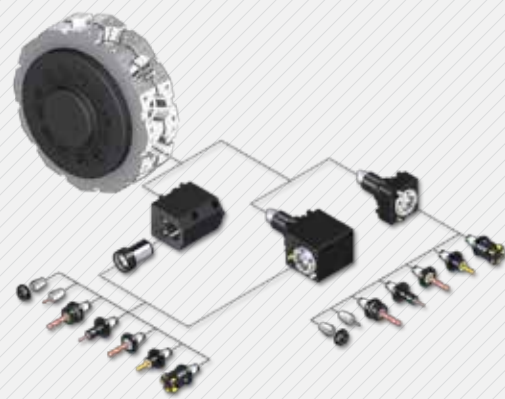

04
L160/L230

Machining Capability

Excellent Performance, High Accuracy Cutting
CNC Turning Center

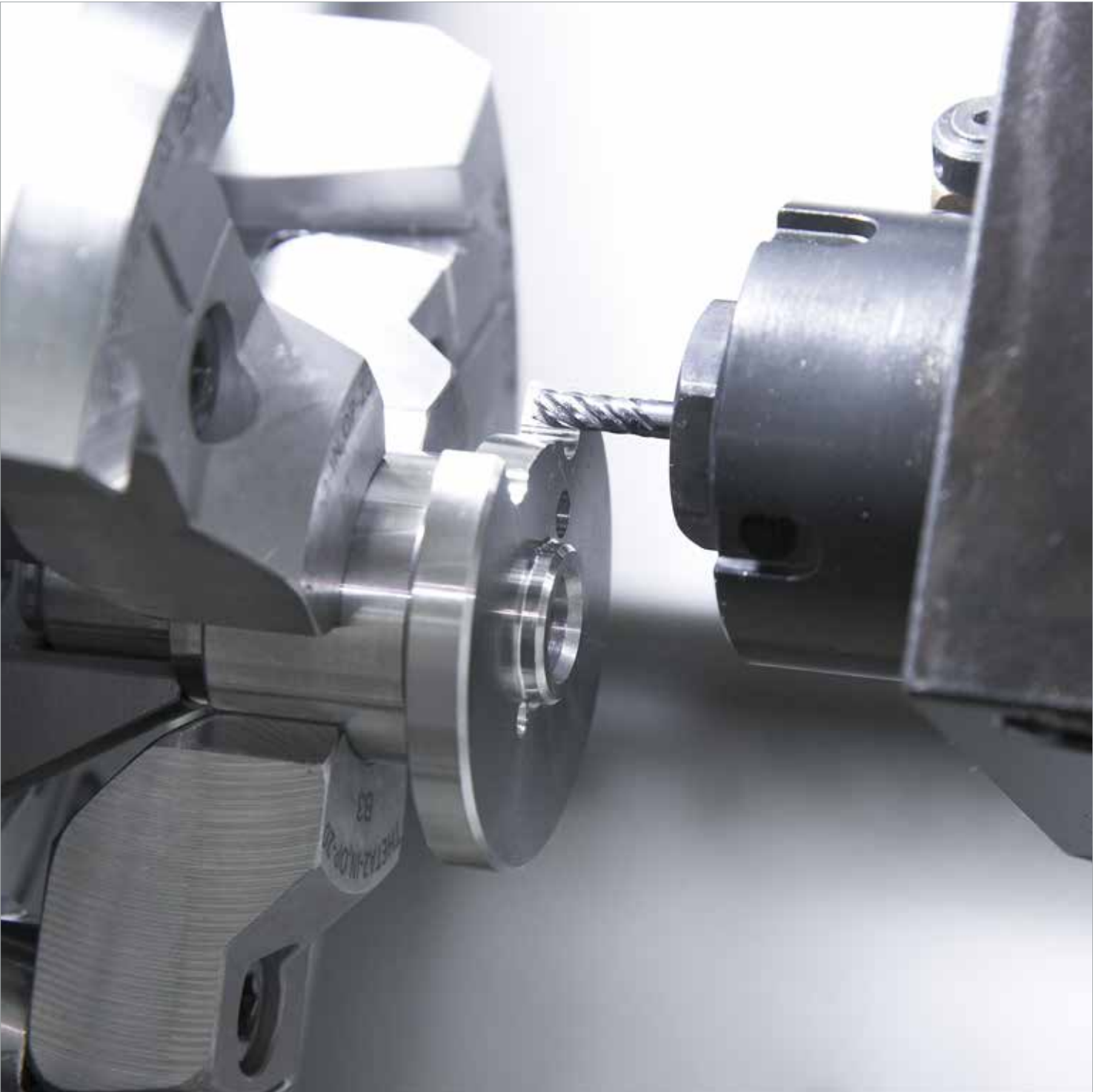

L230LMSA

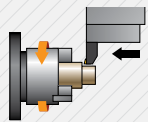

Cutting (O.D)

Turning (Material:JIS:S45C(Carbon steel))

Processing diameter	Ø60 (Ø2.36")
Side cutting depth	6 mm (0.24")
Cutting speed	150 m/min (5,905 ipm)
Spindle rpm	584 r/min
Forwarding speed	0.5 mm/rev
Chip discharge	450 cc/min

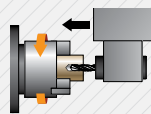

U-Drilling

Drilling (Material:JIS:S45C(Carbon steel))

Drill diameter	Ø40 (Ø1.57")
Cutting speed	104 m/min (4,94 ipm)
Spindle rpm	828 r/min
Forwarding speed	0.3 mm/rev
Chip discharge	311 cc/min

Sample Workpiece



❖ The above result might be different by types of processing circumstance

Machining Variation

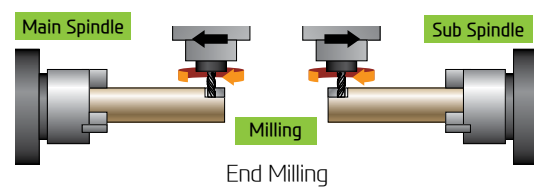
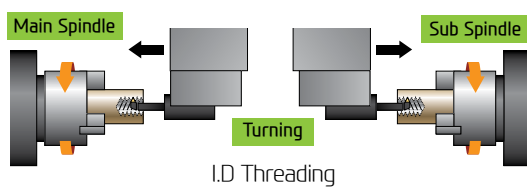
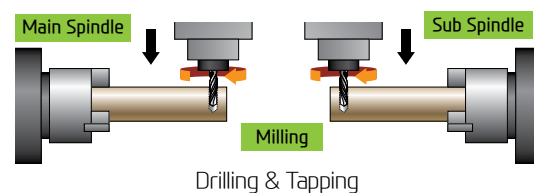
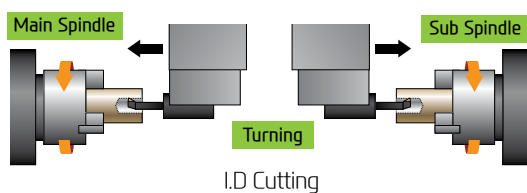
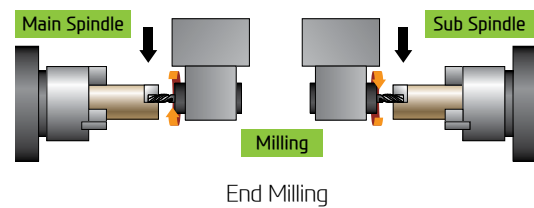
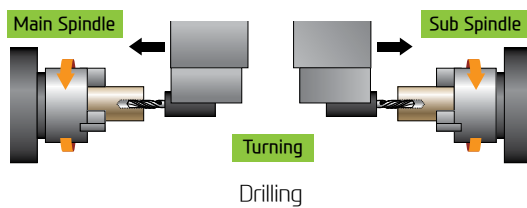
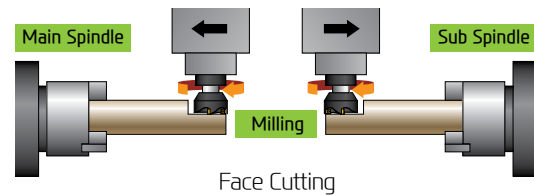
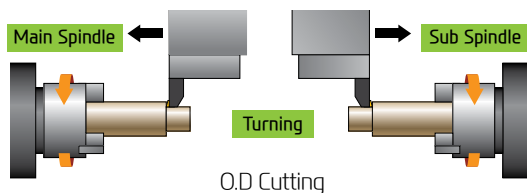

05

L160/L230

Smart System



Software for Smart Operating and Machining

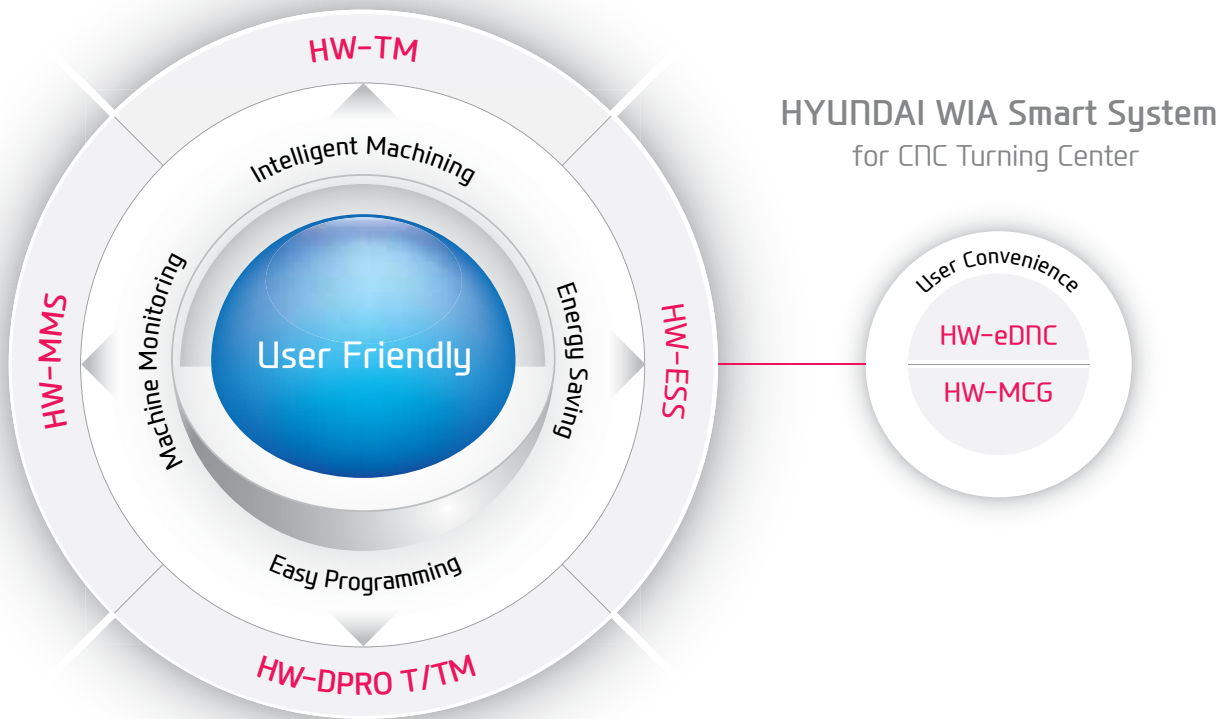

HYUNDAI WIA Smart System
for CNC Turning Center

Smart Factory HW-MMS (HYUNDAI WIA-Machine Monitoring System)

A brand new manufacturing machine by HYUNDAI WIA, HW-MMS is a unique software capable of monitoring the operation status of manufacturing machines in factories, a smart solution to improve manufacturing conditions of customers.

01 Real-time monitoring of machine operation status (Cloud)

02 History and statistics of machine operation (Cloud)

03 History and statistics of alarm occurrence (Cloud)

04 History and statistics of work count (Cloud)

05 Remote diagnosis (Remote)

HW-MMS Remote System

- 01 Real-time monitoring of machine operation status (Cloud)
- 02 History and statistics of machine operation (Cloud)
- 03 History and statistics of alarm occurrence (Cloud)
- 04 History and statistics of work count (Cloud)
- 05 Remote diagnosis (Remote)

Faster processing and enhanced accuracy in are possible through the **HYUNDAI WIA Smart System**. The user friendly software and equipment monitoring of the Smart System maximizes productivity.



HW-eDNC

HYUNDAI WIA ethernet
Direct Numerical Control

This software allows transmission of NC data between PC and a machine's CNC. The processing programs can be managed on the PC through the ethernet or serial communication.



HW-MCG

HYUNDAI WIA
Machine Guidance

Software that offers operation, maintenance, management monitoring and various user friendly features.



HW-TM

HYUNDAI WIA
Tool Monitoring

A tool monitoring software which analyzes the load of the spindle motor to determine and monitor possible damage of tools.



HW-ESS (Standard)

HYUNDAI WIA
Energy Saving System

An environmental friendly software that reduces the unnecessarily wasted standby power waiting for an operation.

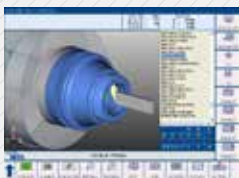

HW-DPRO T/TM HYUNDAI WIA Dialogue PROGRAM Turn/TurnMill

Using a dialogue method, this software makes it easy to work out a program for a lathe processing operation with complicated configurations. (Can be installed on a PC.)

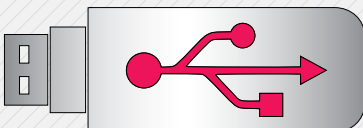

USB Port

Convenience is increased when inputting and outputting program. The USB port is available in addition to the former input output methods such as CF memmort card and LAN.

SIEMENS

DIFFERENTIATED CAPABILITIES, INTEGRATED ENGINEERING PERFECTLY INTERLINKED

SIEMENS 828D is a latest model CNC. It is designed for horizontal/vertical all-purpose equipments.

Its 80-bit control reduces processing time and increases productivity. The 828D is easy to maintain and run, with its easy setup functions.



SIEMENS Technology

Shop Turn

- Dialogue-type programming, simple and convenient
- Effective specifications for small quantity batch production
- Step-by-step operation possible without knowledge of the DIN/ISO code



OPTION

3D Simulation

- 3D confirmation of the completed processing configuration of the NC program is possible.
- Offers standards for 2D simulation.
- Possible to confirm the simulation of the NC program during processing.



OPTION

Easy Extend

- Easy to install/uninstall an option (Ex : barfeeder and chip conveyor, etc.)
- Possible to install in one motion without revision of individual perimeters.
- A spate list is unnecessary as option items are indicated with letters.



SIEMENS Communication Function

Variable Communication Port

RJ 45 Ethernet

USB 2.0

Compact Flash Card



Easy input/output of a program is possible as a USB memory card, a CF memory card and LAN can all be used.

ISO Code Programming



If the ISO Dialect (G291) is ordered, JIS-based G-code programs can be used. (Standard)

SIEMENS Convenience Function

Easy Tool Measuring

- Easy calculation (automatic and manual) of the offset values of the installed equipment
- Automatic input of the measured offset values of equipment into the equipment list



Work Offset Measuring

- Supports the function of work offset calculation
- Automatic application of the measured work offset value as the activated work offset



Real Time PLC Monitoring

- Real time monitoring of PLC programs is possible. Supports the "search" and "cross reference" functions.
- Real time verification of I/O variables and PLC interface
- Input/change of the values of variables



Block Searching

- Program can be re-started from a particular location without editing the processing program.
- Provides safety to the user.



Alarm Log

- A maximum of 500 alarms can be stored.
- The entire alarm log can be stored as a data file in the I/O
- The overall alarm history can be checked through the alarm log.

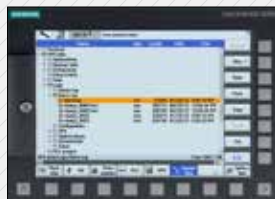

SIEMENS Easy Programming



Program Guide

Simple Program, High Productivity

- Use of cycle program minimizes program capacity.
- When cycle variables are input, graphic images are provided.
- Tool path and simulation of completed cycle program are available.
- Various configurations can be processed using cycles.



Engraving Cycle

Simple Letter Processing is Possible.

- Letters can be processed on products by establishing a plane and inputting letters.
- Letter size/angle/location/direction can be designated.
- Capital and small letters of English can be processed.

n6

L160/L230

Automation System



Various Devices for User Convenience

Bar Feeder System

Bar Feeder

Bar feeder system enables automation which leads to efficiency improvement.

Long Type	3 m (118.1")
Max Bar Capacity	Ø42 mm (1.7")
Short Type	1.5 m (59.1")
Max Bar Capacity	Ø65 mm (2.6")

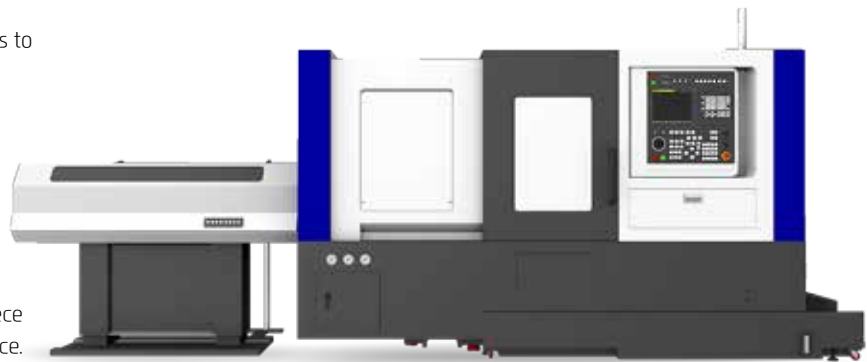

Work Conveyor

The parts conveyor transfers the finished workpiece unloaded by the parts catcher for user convenience.



Gantry Loader System



Gantry Loader Machining Process

The high speed gantry loaders and the work stocker allow the implementation of automation cells. This enables flexible machining process and productivity enhancement. Optimization of the installation space is also possible.

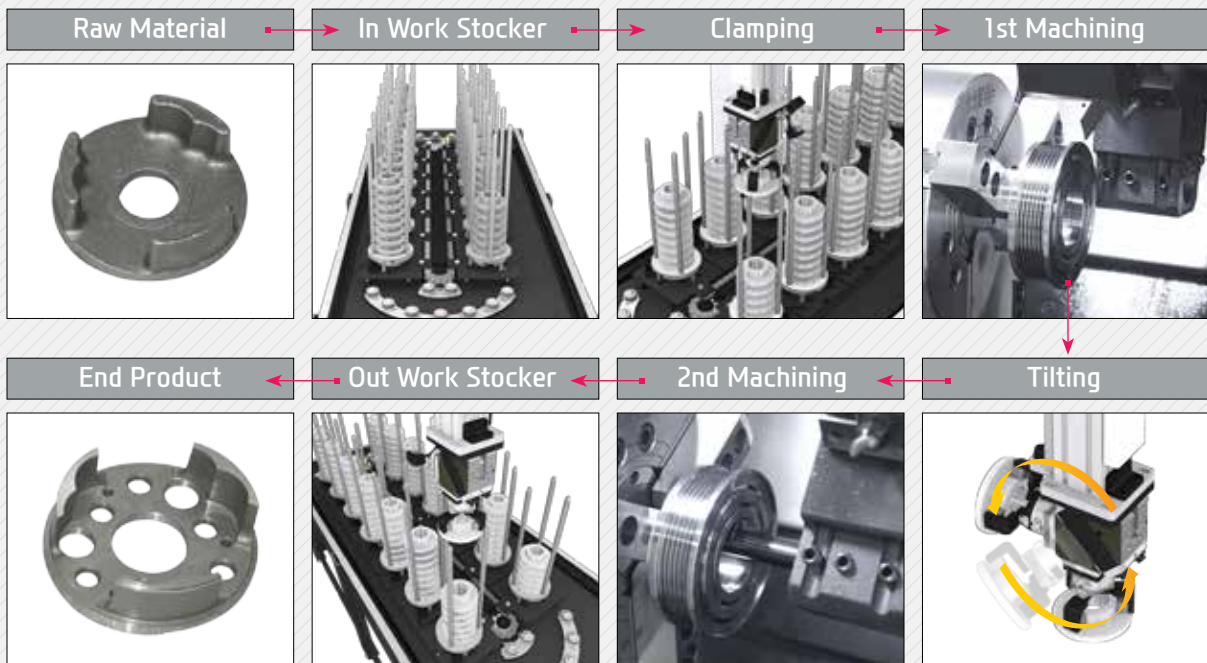

SPECIFICATIONS

L160A Series Standard & Optional

Spindle		A	MA	LA	LMA	LMSA
Main Spindle Hollow Chuck 3 Jaw	6"	●	●	●	●	●
Main Spindle Solid Chuck 3 Jaw	6"	○	○	○	○	○
Sub Spindle Hollow Chuck 3 Jaw	6"	-	-	-	-	●
Sub Spindle Solid Chuck 3 Jaw	6"	-	-	-	-	○
Standard Soft Jaw (1set)		●	●	●	●	●
Chuck Clamp Foot Switch		●	●	●	●	●
2 Steps Hyd. Pressure Device		○	○	○	○	○
Spindle Inside Stopper		☆	☆	☆	☆	☆
Main Spindle Cs-axis (0.001")		-	●	-	●	●
Sub Spindle Cs-axis (0.001")		-	-	-	-	●
Chuck Open/Close Confirmation Device		○(CE●)	○(CE●)	○(CE●)	○(CE●)	○(CE●)
2 Steps Chuck Foot Switch		☆	☆	☆	☆	☆
Sub Spindle Foot Switch		-	-	-	-	○
Turret						
Tool Holder		●	●	●	●	●
Mill Turret	BMT	-	●	-	●	●
Straight Milling Head (Axial)	Collet Type,lea	-	●	-	●	●
Angular Milling Head (Radial)	Collet Type,lea	-	●	-	●	●
Straight Milling Head (Radial)	Adapter Type	-	○	-	○	○
Angular Milling Head (Axial)	Adapter Type	-	○	-	○	○
Boring Sleeve (U-Drill Holder Sleeve)		●	●	●	●	●
Drill Socket		○	○	○	○	○
U-Drill Holder		●	●	●	●	●
U-Drill Cap		●	●	●	●	●
Angle Head		-	☆	-	☆	☆
Tail Stock & Steady Rest						
Semi Programmable Tail Stock		●	●	●	●	-
Quill Type Tail Stock (Foot Switch)	MT-5	○	○	○	○	-
Built-In Tail Stock	MT-4	☆	☆	☆	☆	-
Programmable Tail Stock		-	-	-	-	-
Standard Live Center		●	●	●	●	-
High Precision Live Center		○	○	○	○	-
2 Steps Tail Stock Pressure System		☆	☆	☆	☆	-
Quill Forward/Reverse Confirmation Device		○(CE●)	○(CE●)	○(CE●)	○(CE●)	-
Coolant & Air Blow						
Standard Coolant (Nozzle)		●	●	●	●	●
Chuck Coolant (Upper Chuck)		○	○	○	○	○
Gun Coolant		○	○	○	○	○
Through Spindle Coolant (Only for Special Chuck)		☆	☆	☆	☆	☆
Bed Flushing		○	○	○	○	○
Chuck Air Blow (Upper Chuck)		○	○	○	○	○
Sub Spindle Air Blow		-	-	-	-	○
Turret Air Blow		☆	☆	☆	☆	☆
Air Gun		○	○	○	○	○
Through Spindle Air Blow (Only for Special Chuck)		☆	☆	☆	☆	☆
High Pressure Coolant	0.4Bar (5.8psi)	●	●	●	●	●
	6Bar (87psi)	○	○	○	○	○
	20Bar (290psi)	○	○	○	○	○
Power Coolant System (For Automation)		☆	☆	☆	☆	☆
Chip Disposal						
Coolant Tank	Front (150 ℓ [39.6 gal])	●	●	-	-	-
	Front (200 ℓ /20 bar [52.8 gal /290 psi])	○	○	-	-	-
	Front (270 ℓ [71.3 gal])	-	-	●	●	●
	Rear (200 ℓ [52.8 gal])	○	○	-	-	-
	Rear (250 ℓ [66 gal])	-	-	○	○	○
Chip Conveyor (Hinge/Scraper)	Front (Right)	○	○	○	○	○
	Rear (Rear)	○	○	○	○	○
Special Chip Conveyor (Drum Filter)		☆	☆	☆	☆	☆
Chip Wagon	Standard (180 ℓ [47.5 gal])	○	○	○	○	○
	Swing (200 ℓ [52.8 gal])	○	○	○	○	○
	Large Swing (290 ℓ [76.6 gal])	○	○	○	○	○
	Large Size (330 ℓ [87.2 gal])	○	○	○	○	○
	Customized	☆	☆	☆	☆	☆

● : Standard ○ : Option ☆ : Prior Consultation - : Non Applicable

Safety Device		A	MA	LA	LMA	LMSA
Total Splash Guard		●	●	●	●	●
Chuck hydraulic pressure maintenance interlock		○(CE●)	○(CE●)	○(CE●)	○(CE●)	○(CE●)
Electric Device						
Call Light	1 Color : ●	●	●	●	●	●
	2 Color : ●●	○	○	○	○	○
Call Light	3 Color : ●●●	○	○	○	○	○
Call Light & Buzzer	3 Color : ●●●B	○	○	○	○	○
Electric Cabinet Light		○	○	○	○	○
Remote MPG		-	-	-	-	-
Work Counter	Digital	○	○	○	○	○
Total Counter	Digital	○	○	○	○	○
Tool Counter	Digital	○	○	○	○	○
Multi Tool Counter	Digital	○	○	○	○	○
Electric Circuit Breaker		○	○	○	○	○
AVR (Auto Voltage Regulator)		☆	☆	☆	☆	☆
Transformer	25kVA	○	○	○	○	-
	30kVA	-	-	-	-	○
Auto Power Off		○	○	○	○	○
Measurement						
Q-Setter		○	○	○	○	○
Automatic Q-Setter		●	●	●	●	●
Work Close Confirmation Device (Only for Special Chuck)	TACO	○	○	○	○	○
	SMC	○	○	○	○	○
Work Setter		☆	☆	☆	☆	☆
Linear Scale	X Axis	○	○	○	○	○
	Z Axis	○	○	○	○	○
Coolant Level Sensor (Only for Chip Conveyor)		☆	☆	☆	☆	☆
Environment						
Air Conditioner	FANUC	○	○	○	○	○
	SIEMENS	●	●	●	●	●
Oil Mist Collector		☆	☆	☆	☆	☆
Oil-Water Separation Device		●	●	●	●	●
Oil Skimmer		○	○	○	○	○
MLQ (Minimal Quantity Lubrication)		☆	☆	☆	☆	☆
Fixture & Automation						
Auto Door	High Speed	○	○	○	○	○
Auto Shutter (Only for Automatic System)		○	○	○	○	○
Sub Operation Panel		☆	☆	☆	☆	☆
Bar Feeder Interface		○	○	○	○	○
Bar Feeder (FEDEK)		☆	☆	☆	☆	☆
Extra M-Code 4ea		○	○	○	○	○
Automation Interface		☆	☆	☆	☆	☆
I/O Extension (IN & OUT)	16 Contact	○	○	○	○	○
	32 Contact	○	○	○	○	○
Parts Catcher		○	○	○	○	○
Sub Spindle Work Pusher (Spring Type)		-	-	-	-	○
Sub Spindle Work Ejector (Pneumatic Type)		-	-	-	-	○
Turret Work Pusher (For Automation)		☆	☆	☆	☆	☆
Parts Conveyor (Main Part Catcher Application)		○	○	○	○	○
Semi Automation System		☆	☆	☆	☆	☆
Hyd. Device						
Standard Hyd. Cylinder	Hollow	●	●	●	●	●
Standard Hyd. Unit	35bar (507.6 psi)/18 ℓ (4.8gal)	●	●	●	●	●
S/W						
Machine Guidance (HW-MCG)		☆	☆	☆	☆	☆
Energy Saving System (HW-ESS)		●	●	●	●	●
Tool Monitoring (HW-TM)		○	○	○	○	○
DNC software (HW-eDNC)		○	○	○	○	○
Machine Monitoring System (HW-MMS)		☆	☆	☆	☆	☆
Conversational Program (HW-DPRO)		○	○	○	○	-
ETC						
Tool Box		●	●	●	●	●
Customized Color	Need Munsel No.	☆	☆	☆	☆	☆
CAD & CAM		☆	☆	☆	☆	☆

SPECIFICATIONS

L230A Series Standard & Optional

Spindle		A	MA	LA	LMA	LMSA
Main Spindle Hollow Chuck 3 Jaw	8"	●	●	●	●	●
Main Spindle Solid Chuck 3 Jaw	8"	○	○	○	○	○
Sub Spindle Hollow Chuck 3 Jaw	6"	-	-	-	-	●
Sub Spindle Solid Chuck 3 Jaw	6"	-	-	-	-	○
Standard Soft Jaw (1set)		●	●	●	●	●
Chuck Clamp Foot Switch		●	●	●	●	●
2 Steps Hyd. Pressure Device		○	○	○	○	○
Spindle Inside Stopper		☆	☆	☆	☆	☆
Main Spindle Cs-axis (0.001")		-	●	-	●	●
Sub Spindle Cs-axis (0.001")		-	-	-	-	●
Chuck Open/Close Confirmation Device		○(CE:●)	○(CE:●)	○(CE:●)	○(CE:●)	○(CE:●)
2 Steps Chuck Foot Switch		☆	☆	☆	☆	☆
Sub Spindle Foot Switch		-	-	-	-	○
Turret						
Tool Holder		●	●	●	●	●
Mill Turret	BMT	-	●	-	●	●
Straight Milling Head (Axial)	Collet Type, 1ea	-	●	-	●	●
Angular Milling Head (Radial)	Collet Type, 1ea	-	●	-	●	●
Straight Milling Head (Radial)	Adapter Type	-	○	-	○	○
Angular Milling Head (Axial)	Adapter Type	-	○	-	○	○
Boring Sleeve (U-Drill Holder Sleeve)		●	●	●	●	●
Drill Socket		○	○	○	○	○
U-Drill Holder		●	●	●	●	●
U-Drill Cap		●	●	●	●	●
Angle Head		-	☆	-	☆	☆
Tail Stock & Steady Rest						
Semi Programmable Tail Stock		●	●	●	●	-
Quill Type Tail Stock (Foot Switch)	MT-5	○	○	☆	☆	-
Built-In Tail Stock	MT-4	☆	☆	☆	☆	-
Programmable Tail Stock		-	-	-	-	-
Standard Live Center		●	●	●	●	-
High Precision Live Center		○	○	○	○	-
2 Steps Tail Stock Pressure System		☆	☆	☆	☆	-
Quill Forward/Reverse Confirmation Device		○(CE:●)	○(CE:●)	○(CE:●)	○(CE:●)	-
Coolant & Air Blow						
Standard Coolant (Nozzle)		●	●	●	●	●
Chuck Coolant (Upper Chuck)		○	○	○	○	○
Gun Coolant		○	○	○	○	○
Through Spindle Coolant (Only for Special Chuck)		☆	☆	☆	☆	☆
Bed Flushing		○	○	○	○	○
Chuck Air Blow (Upper Chuck)		○	○	○	○	○
Sub Spindle Air Blow		-	-	-	-	○
Turret Air Blow		☆	☆	☆	☆	☆
Air Gun		○	○	○	○	○
Through Spindle Air Blow (Only for Special Chuck)		☆	☆	☆	☆	☆
High Pressure Coolant	0.4Bar (5.8psi)	●	●	●	●	●
	6Bar (87psi)	○	○	○	○	○
	20Bar (290psi)	○	○	○	○	○
Power Coolant System (For Automation)		☆	☆	☆	☆	☆
Chip Disposal						
Coolant Tank	Front (150 ℓ [39.6 gal])	●	●	-	-	-
	Front (200 ℓ /20 bar [52.8 gal /290 psi])	○	○	-	-	-
	Front (270 ℓ [71.3 gal])	-	-	●	●	●
	Rear (200 ℓ [52.8 gal])	○	○	-	-	-
	Rear (250 ℓ [66 gal])	-	-	○	○	○
Chip Conveyor (Hinge/Scraper)	Front (Right)	○	○	○	○	○
	Rear (Rear)	○	○	○	○	○
Special Chip Conveyor (Drum Filter)		☆	☆	☆	☆	☆
Chip Wagon	Standard (180 ℓ [47.5 gal])	○	○	○	○	○
	Swing (200 ℓ [52.8 gal])	○	○	○	○	○
	Large Swing (290 ℓ [76.6 gal])	○	○	○	○	○
	Large Size (330 ℓ [87.2 gal])	○	○	○	○	○
	Customized	☆	☆	☆	☆	☆

● : Standard ○ : Option ☆ : Prior Consultation - : Non Applicable

Safety Device		A	MA	LA	LMA	LMSA
Total Splash Guard		●	●	●	●	●
Chuck hydraulic pressure maintenance interlock		○(CE:●)	○(CE:●)	○(CE:●)	○(CE:●)	○(CE:●)
Electric Device						
Call Light	1 Color : ●	●	●	●	●	●
Call Light	2 Color : ●●	○	○	○	○	○
Call Light	3 Color : ●●●	○	○	○	○	○
Call Light & Buzzer	3 Color : ●●●B	○	○	○	○	○
Electric Cabinet Light		○	○	○	○	○
Remote MPG		-	-	-	-	-
Work Counter	Digital	○	○	○	○	○
Total Counter	Digital	○	○	○	○	○
Tool Counter	Digital	○	○	○	○	○
Multi Tool Counter	Digital	○	○	○	○	○
Electric Circuit Breaker		○	○	○	○	○
AVR (Auto Voltage Regulator)		☆	☆	☆	☆	☆
Transformer	25KVA	○	-	○	-	-
	30KVA	-	○	-	○	-
	35KVA	-	-	-	-	○
Auto Power Off		○	○	○	○	○
Measurement						
Q-Setter		○	○	○	○	○
Automatic Q-Setter		●	●	●	●	●
Work Close Confirmation Device (Only for Special Chuck)	TACO	○	○	○	○	○
	SMC	○	○	○	○	○
Work Setter		☆	☆	☆	☆	☆
Linear Scale	X Axis	○	○	○	○	○
	Z Axis	○	○	○	○	○
Coolant Level Sensor (Only for Chip Conveyor)		☆	☆	☆	☆	☆
Environment						
Air Conditioner	FANUC	○	○	○	○	○
	SIEMENS	●	●	●	●	●
Oil Mist Collector		☆	☆	☆	☆	☆
Oil-Water Separation Device		●	●	●	●	●
Oil Skimmer		○	○	○	○	○
MQL(Minimal Quantity Lubrication)		☆	☆	☆	☆	☆
Fixture & Automation						
Auto Door	High Speed	○	○	○	○	○
Auto Shutter (Only for Automatic System)		○	○	○	○	○
Sub Operation Pannel		☆	☆	☆	☆	☆
Bar Feeder Interface		○	○	○	○	○
Bar Feeder (FEDEK)		☆	☆	☆	☆	☆
Extra M-Code 4ea		○	○	○	○	○
Automation Interface		☆	☆	☆	☆	☆
I/O Extension (IN & OUT)	16 Contact	○	○	○	○	○
	32 Contact	○	○	○	○	○
Parts Catcher		○	○	○	○	○
Sub Spindle Work Pusher (Spring Type)		-	-	-	-	○
Sub Spindle Work Ejector (Pneumatic Type)		-	-	-	-	○
Turret Work Pusher (For Automation)		☆	☆	☆	☆	☆
Parts Conveyor (Main Part Catcher Application)		○	○	○	○	○
Semi Automation System		☆	☆	☆	☆	☆
Hyd. Device						
Standard Hyd. Cylinder	Hollow	●	●	●	●	●
Standard Hyd. Unit	35bar (507.6 psi)/ 18 ℓ (4.8gal)	●	●	●	●	●
S/W						
Machine Guidance (HW-MCG)		☆	☆	☆	☆	☆
Energy Saving System (HW-ESS)		●	●	●	●	●
Tool Monitoring (HW-TM)		○	○	○	○	○
DTC software (HW-eDTC)		○	○	○	○	○
Machine Monitoring System (HW-MMS)		☆	☆	☆	☆	☆
Conversational Program (HW-DPRO)		○	○	○	○	-
ETC						
Tool Box		●	●	●	●	●
Customized Color	Need Munsel No.	☆	☆	☆	☆	☆
CAD & CAM		☆	☆	☆	☆	☆

SPECIFICATIONS

L230C/MC Standard & Optional

Spindle		C	MC
Main Spindle Hollow Chuck 3 Jaw	10"	●	●
Main Spindle Solid Chuck 3 Jaw	10"	○	○
Sub Spindle Hollow Chuck 3 Jaw	6"	-	-
Sub Spindle Solid Chuck 3 Jaw	6"	-	-
Standard Soft Jaw (1set)		●	●
Chuck Clamp Foot Switch		●	●
2 Steps Hyd. Pressure Device		○	○
Spindle Inside Stopper		☆	☆
Main Spindle Cs-axis (0.001")		-	●
Sub Spindle Cs-axis (0.001")		-	-
Chuck Open/Close Confirmation Device		○ (CE:●)	○ (CE:●)
2 Steps Chuck Foot Switch		☆	☆
Sub Spindle Foot Switch		-	-
Turret			
Tool Holder		●	●
Mill Turret	BMT	-	●
Straight Milling Head (Axial)	Collet Type,lea	-	●
Angular Milling Head (Radial)	Collet Type,lea	-	●
Straight Milling Head (Radial)	Adapter Type	-	○
Angular Milling Head (Axial)	Adapter Type	-	○
Boring Sleeve (U-Drill Holder Sleeve)		●	●
Drill Socket		○	○
U-Drill Holder		●	●
U-Drill Cap		●	●
Angle Head		-	☆
Tail Stock & Steady Rest			
Semi Programmable Tail Stock		●	●
Quill Type Tail Stock (Foot Switch)	MT-5	○	○
Built-In Tail Stock	MT-4	☆	☆
Programmable Tail Stock		-	-
Standard Live Center		●	-
High Precision Live Center		○	-
2 Steps Tail Stock Pressure System		☆	☆
Quill Forward/Reverse Confirmation Device		○ (CE:●)	○ (CE:●)
Coolant & Air Blow			
Standard Coolant (Nozzle)		●	●
Chuck Coolant (Upper Chuck)		○	○
Gun Coolant		○	○
Through Spindle Coolant (Only for Special Chuck)		☆	☆
Bed Flushing		○	○
Chuck Air Blow (Upper Chuck)		○	○
Sub Spindle Air Blow		-	-
Turret Air Blow		☆	☆
Air Gun		○	○
Through Spindle Air Blow (Only for Special Chuck)		☆	☆
High Pressure Coolant	0.4Bar (5.8psi)	●	●
	6Bar (87psi)	○	○
	20Bar (290psi)	○	○
Power Coolant System (For Automation)		☆	☆
Chip Disposal			
Coolant Tank	Front (150 ℓ [39.6 gal])	●	●
	Front (200 ℓ /20 bar [52.8 gal /290 psi])	○	○
	Rear (200 ℓ [52.8gal])	○	○
Chip Conveyor (Hinge/Scraper)	Front (Right)	○	○
	Rear (Rear)	○	○
Special Chip Conveyor (Drum Filter)		☆	☆
Chip Wagon	Standard (180 ℓ [47.5 gal])	○	○
	Swing (200 ℓ [52.8 gal])	○	○
	Large Swing (290 ℓ [76.6 gal])	○	○
	Large Size (330 ℓ [87.2 gal])	○	○
	Customized	☆	☆

● : Standard ○ : Option ☆ : Prior Consultation - : Non Applicable

Safety Device		C	MC
Total Splash Guard		●	●
Chuck hydraulic pressure maintenance interlock		○ (CE:●)	○ (CE:●)
Electric Device			
Call Light	1 Color : ■	●	●
Call Light	2 Color : ■ ■	○	○
Call Light	3 Color : ■ ■ ■	○	○
Call Light & Buzzer	3 Color : ■ ■ ■ B	○	○
Electric Cabinet Light		○	○
Remote MPG		-	-
Work Counter	Digital	○	○
Total Counter	Digital	○	○
Tool Counter	Digital	○	○
Multi Tool Counter	Digital	○	○
Electric Circuit Breaker		○	○
AVR (Auto Voltage Regulator)		☆	☆
Transformer	30kVA	○	○
Auto Power Off		○	○
Measurement			
Q-Setter		○	○
Automatic Q-Setter		●	●
Work Close Confirmation Device (Only for Special Chuck)	TACO	○	○
	SMC	○	○
Work Setter		☆	☆
Linear Scale	X Axis	○	○
	Z Axis	○	○
Coolant Level Sensor (Only for Chip Conveyor)		☆	☆
Environment			
Air Conditioner	FANUC SIEMENS	○ ●	○ ●
Oil Mist Collector		☆	☆
Oil-Water Separation Device		●	●
Oil Skimmer		○	○
MQL (Minimal Quantity Lubrication)		☆	☆
Fixture & Automation			
Auto Door	High Speed	○	○
Auto Shutter (Only for Automatic System)		○	○
Sub Operation Pannel		☆	☆
Bar Feeder Interface		○	○
Bar Feeder (FEDEK)		☆	☆
Extra M-Code 4ea		○	○
Automation Interface		☆	☆
I/O Extension (IN & OUT)	16 Contact	○	○
	32 Contact	○	○
Parts Catcher		○	○
Sub Spindle Work Pusher (Spring Type)		-	-
Sub Spindle Work Ejector (Pneumatic Type)		-	-
Turret Work Pusher (For Automation)		☆	☆
Parts Conveyor (Main Part Catcher Application)		○	○
Semi Automation System		☆	☆
Hyd. Device			
Standard Hyd. Cylinder	Hollow	●	●
Standard Hyd. Unit	35bar (507.6 psi)/ 18 ℓ (4.8gal)	●	●
S/W			
Machine Guidance (HW-MCG)		☆	☆
Energy Saving System (HW-ESS)		●	●
Tool Monitoring (HW-TM)		○	○
DNC software (HW-eDNC)		○	○
Machine Monitoring System (HW-MMS)		☆	☆
Conversational Program (HW-DPRO)		☆	☆
ETC			
Tool Box		●	●
Customized Color	Need Munsel No.	☆	☆
CAD & CAM		☆	☆

SPECIFICATIONS

External Dimensions

unit : mm(in)

L160A/MA L230A/MA L230C/MC

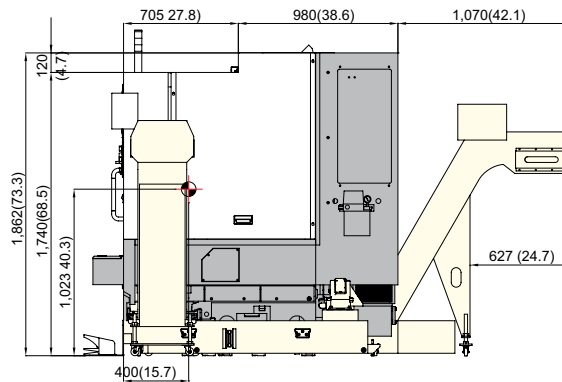
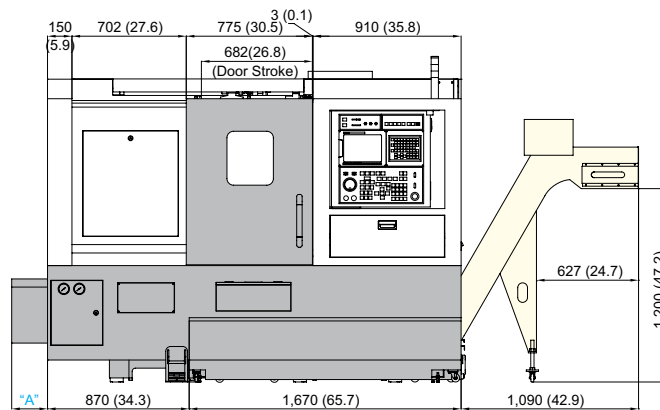
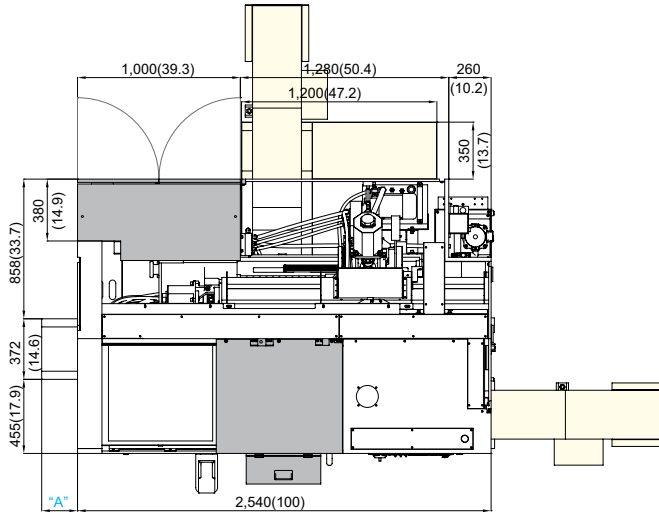

A L160A : 190mm(7.5") L230A : 220mm(8.7") L230C : 360mm(14.2")

SPECIFICATIONS

External Dimensions

unit : mm(in)

L160LA/LMA/LMSA L230LA/LMA/LMSA

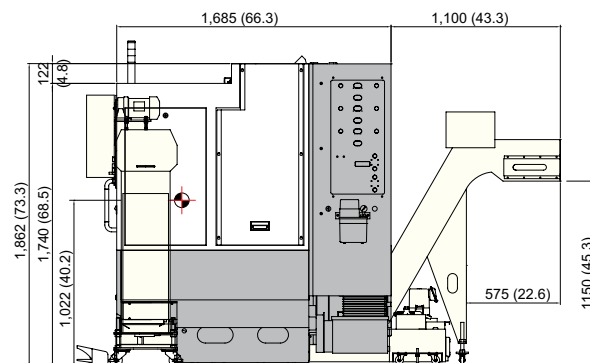
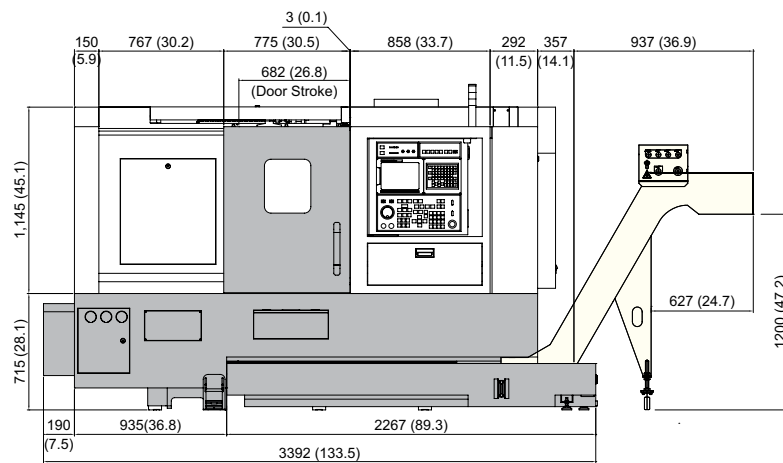
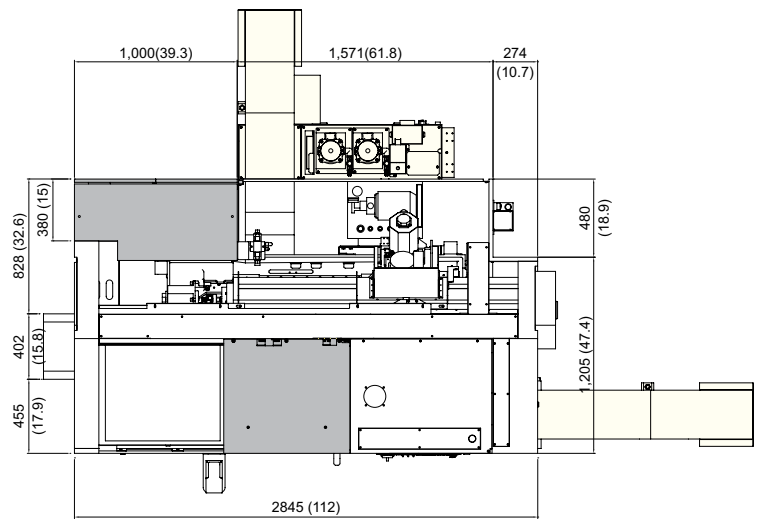

SPECIFICATIONS

Tooling System

unit : mm(in)



L160/230 Series Tooling Parts Detail

ITEM			A/LA		L230C/LC	
			mm Unit	inch Unit	mm Unit	inch Unit
Turning Holder	O.D Holder	Right/Left	-	-	-	-
		Extension	-	-	1	1
	Facing Holder		1	1	1	1
	Cutting Holder		-	-	-	-
Boring Holder	I.D Holder	Single	5	5	5	5
	U-Drill Holder	Cap (Single)	1	1	1	1
Driven Holder	Straight Mill Holder	Standard	-	-	-	-
		TTC (Tool through coolant)	-	-	-	-
	Angular Mill Holder	Standard	-	-	-	-
		TTC (Tool through coolant)	-	-	-	-
Socket	Boring (mm)	Ø10 (Ø3/8")	1	-	1	-
		Ø12 (Ø1/2")	1	1	1	1
		Ø16 (Ø5/8")	1	-	1	-
		Ø20 (Ø3/4")	1	1	1	1
		Ø25 (Ø1")	1	1	1	1
		Ø32 (Ø1 1/4")	1	1	1	1
	Drill	MT 2	1	1	1	1

SPECIFICATIONS

Tooling System

unit : mm(in)

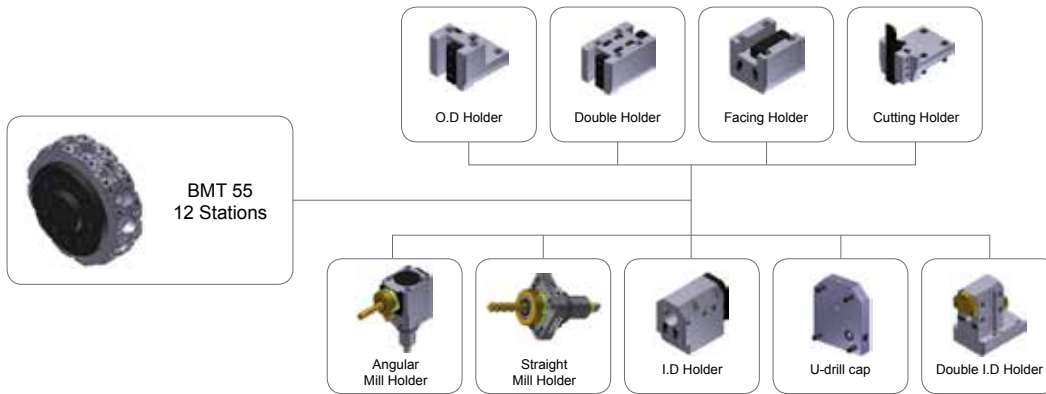

L160/230 Series Tooling Parts Detail

ITEM			MA/LMA/230MC		LMSA	
			mm Unit	inch Unit	mm Unit	inch Unit
Turning Holder	O.D Holder	Right/Left	4	4	2	2
		Double	-	-	1	1
	Facing Holder	1	1	1	1	
	Cutting Holder	1	1	1	1	
Boring Holder	I.D Holder	Single	4	4	4	4
		Double	-	-	1	1
Driven Holder	U-Drill Holder	Cap (Single)	1	1	1	1
		Cap (Double)	-	-	1	1
	Straight Mill Holder	Standard	1	1	1	1
		TTC (Tool through coolant)	Opt.	Opt.	Opt.	Opt.
	Angular Mill Holder	Standard	1	1	1	1
		TTC (Tool through coolant)	Opt.	Opt.	Opt.	Opt.
Socket	Boring	Ø8×Ø20 (Ø5/16"×Ø3/4")	-	-	1	1
		Ø12×Ø20 (Ø1/2"×Ø3/4")	-	-	1	1
		Ø16×Ø20 (Ø5/8"×Ø3/4")	-	-	1	1
		Ø10×Ø40 (Ø5/8"×Ø1 1/2")	1	1	1	1
		Ø12×Ø40 (Ø3/8"×Ø1 1/2")	1	1	1	1
		Ø16×Ø40 (Ø1/2"×Ø1 1/2")	1	1	1	1
		Ø20×Ø40 (Ø3/4"×Ø1 1/2")	1	1	1	1
		Ø25×Ø40 (Ø1"×Ø1 1/2")	1	1	1	1
	Drill	MT 1 x MT 2	Opt.	Opt.	Opt.	Opt.
		MT 2	Opt.	Opt.	Opt.	Opt.
		MT 3	Opt.	Opt.	Opt.	Opt.
	ER Collet	ER25	1 Set	1 Set	1 Set	1 Set

SPECIFICATIONS

Interference

unit : mm(in)

L160A/230A

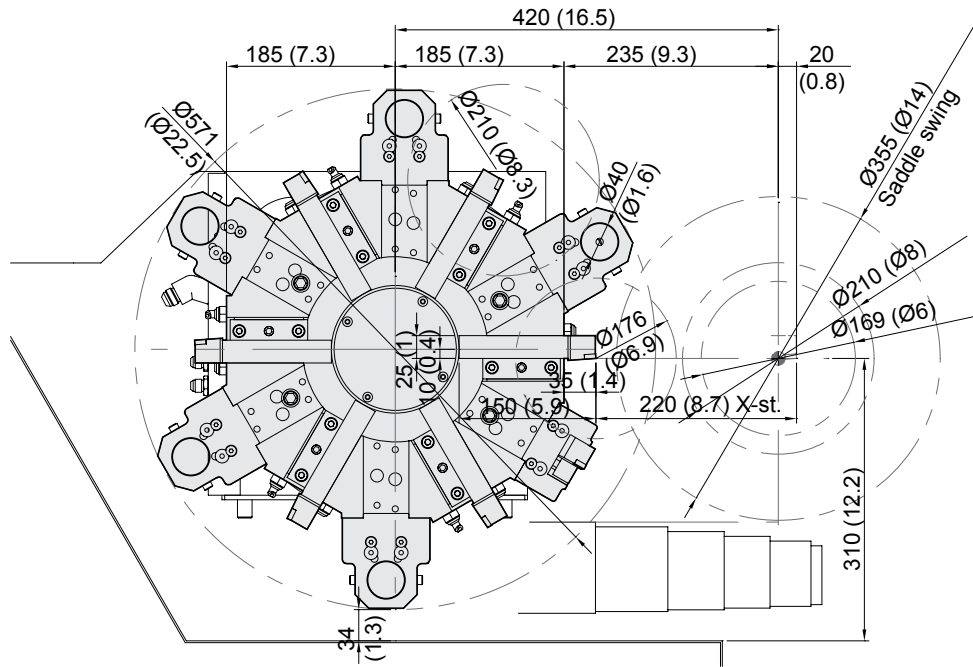

L230C

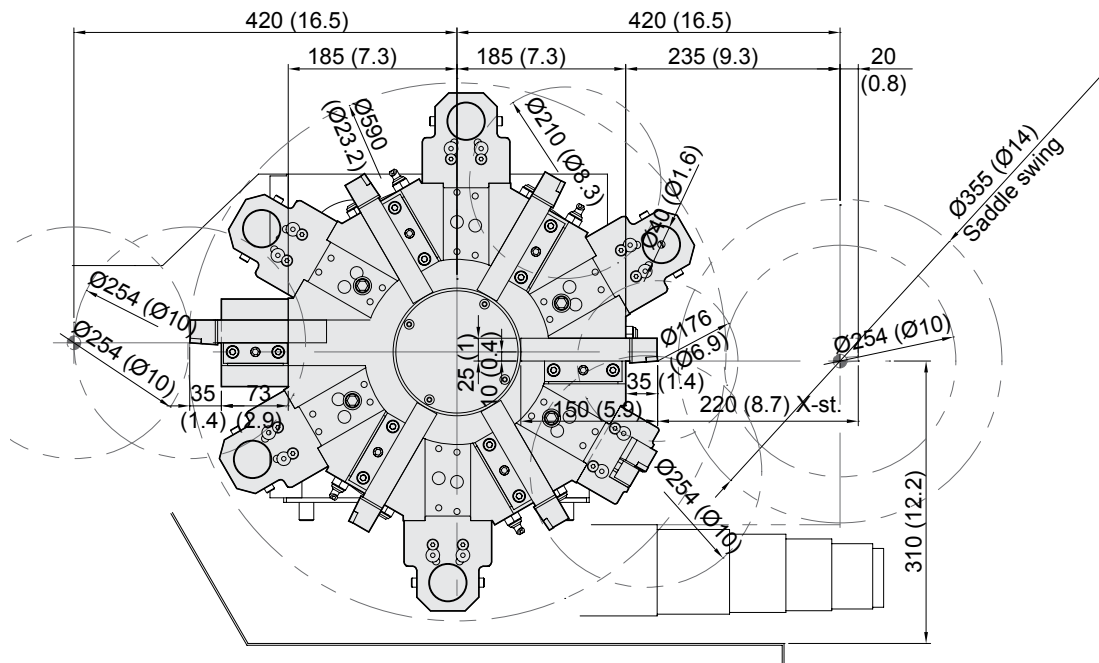

SPECIFICATIONS

Interference

unit : mm(in)

L160MA/LMA
L230MA/MC/LMA

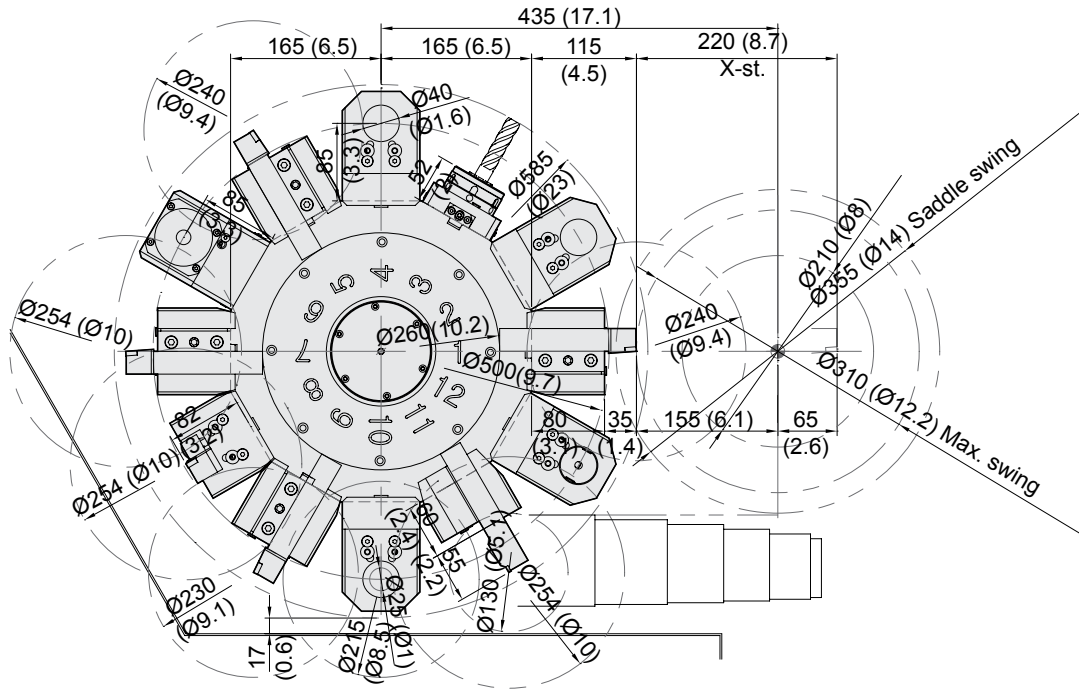

L160LMSA
L230LMSA

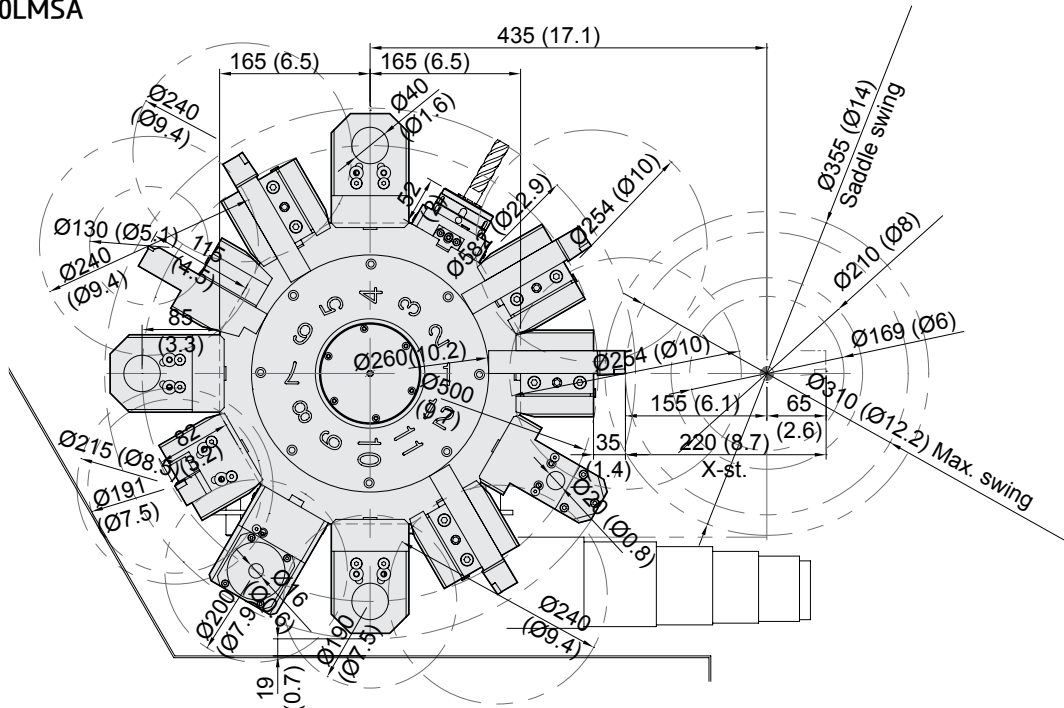

SPECIFICATIONS

Tooling Travel Range

unit : mm(in)

L160A

OD tool

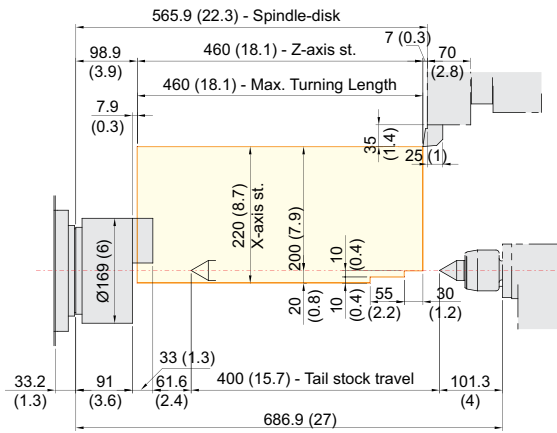

ID tool

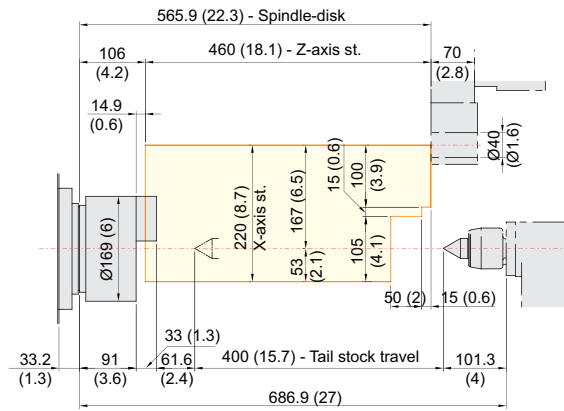

L230A/C

OD tool

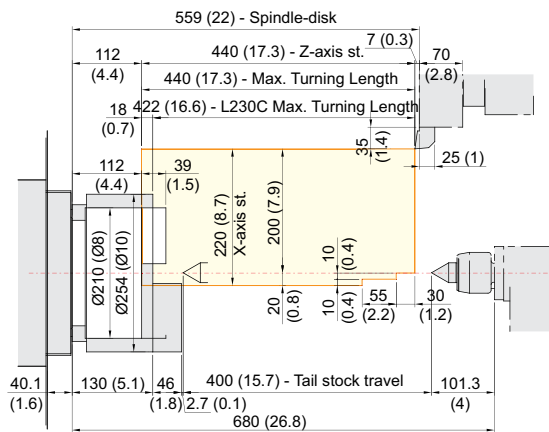

ID tool

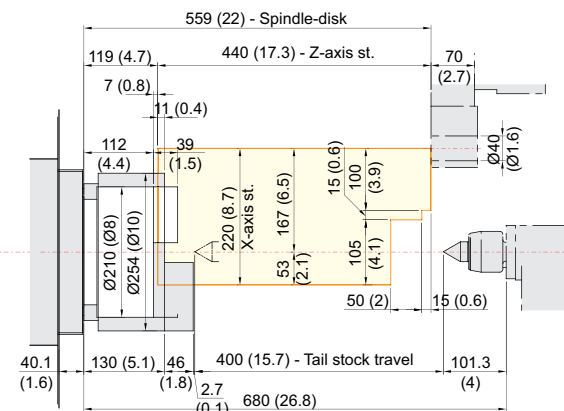

SPECIFICATIONS

Tooling Travel Range

unit : mm(in)

L160MA

OD tool

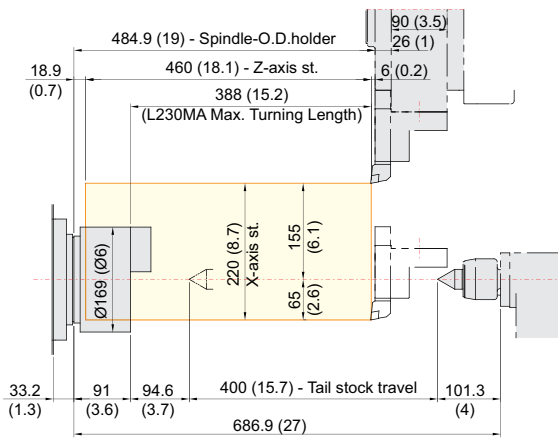

ID tool

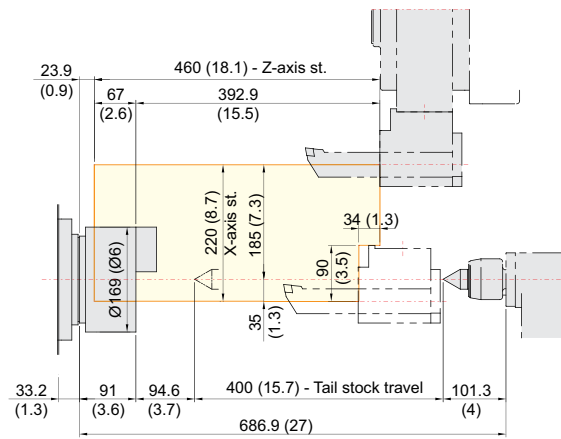

Straight Mill Holder

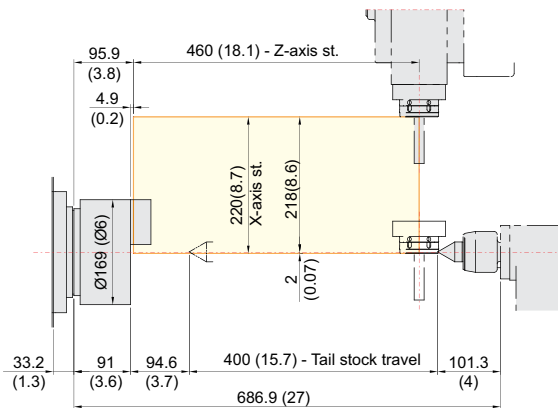

Angular Mill Holder

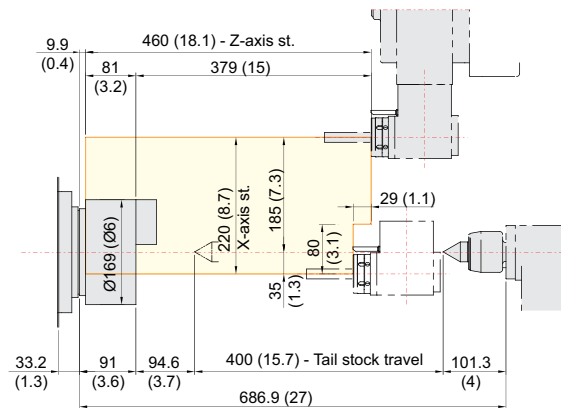

SPECIFICATIONS

Tooling Travel Range

unit : mm(in)

L230MA/MC

OD tool

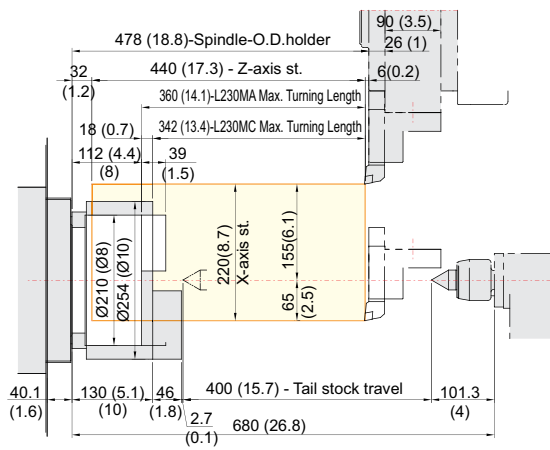

ID tool

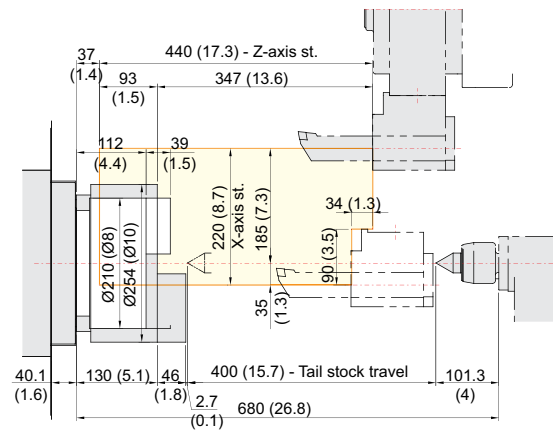

Straight Mill Holder

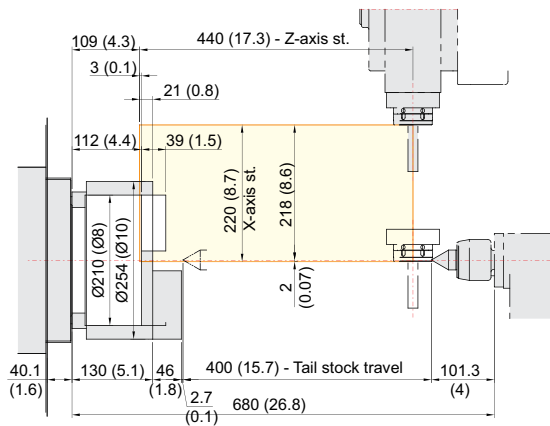

Angular Mill Holder

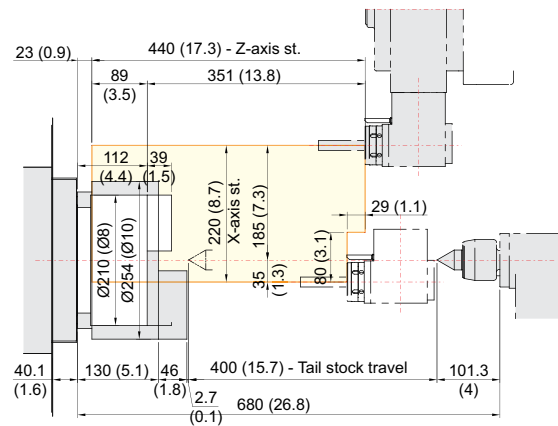

SPECIFICATIONS

Tooling Travel Range

unit : mm(in)

L160LMSA/230LMSA

OD tool

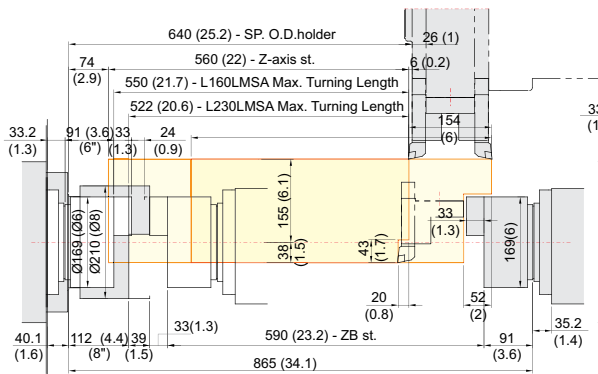

ID tool

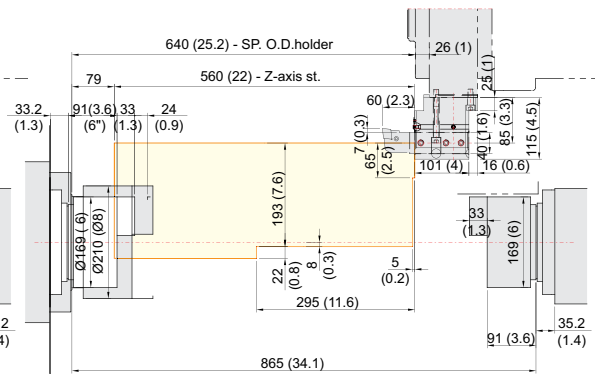

Straight Mill Holder

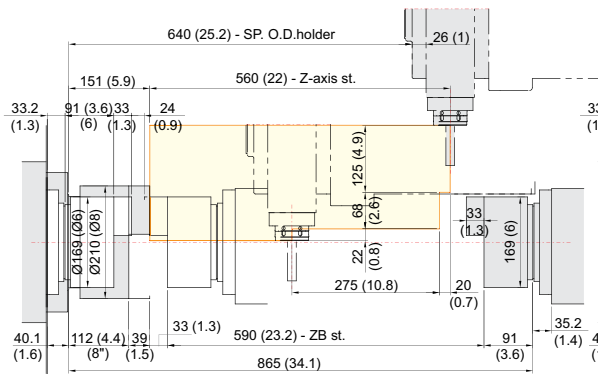

Angular Mill Holder

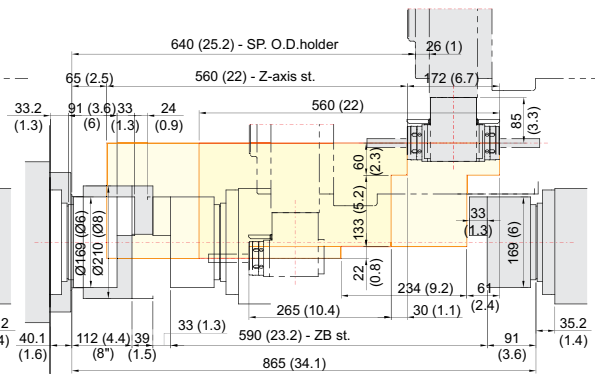

SPECIFICATIONS

Specifications

[] : Option

ITEM			L160A	L160MA	L160LA	L160LMA	L160LMSA
CAPACITY	Swing Over the Bed	mm(in)	Ø600 (23.6")				
	Swing Over the Carriage	mm(in)	Ø355 (14")				
	Max. Turning Dia.	mm(in)	Ø355 (14")	Ø310 (12.2")	Ø355 (14")	Ø310 (12.2")	
	Max. Turning Length	mm(in)	460 (18.1")	388 (15.3")	560 (22")	550 (21.7")	
	Bar Capacity	Main	mm(in)	Ø45 (1.8")			
Sub		mm(in)	-				Ø43 (1.7")
SPINDLE	Chuck Size	Main	inch		6"		
		Sub	inch		-		6"
	Spindle Bore	Main	mm(in)		Ø53 (2.1")		
		Sub	mm(in)		-		Ø53 (2.1")
	Spindle Speed (rpm)	Main	r/min		6,000 [6,000]		
		Sub	r/min		-		5,000 [5,000]
	Motor (Max/Cont.)	Main	kW(HP)		11/7.5(14.7/10) [10.8/9(14.5/12)]		
		Sub	kW(HP)		-		5.5/3.7(7.4/5) [5.9/4.9 (7.9/6.6)]
	Torque (Max/Cont.)	Main	N·m(lbf·ft)		70/47.7(51.6/35.2) [69/57.3(50.9/42.3)]		
		Sub	N·m(lbf·ft)		-		47.2/31.8 (34.8/23.5) [38/31.6 (28/23.3)]
	Spindle Type	Main	-		BELT		
		Sub	-		-		BELT
	Spindle Nose	Main	-		A2-5		
Sub		-		-		A2-5	
C-axis Indexing	deg	-	0.001°	-	0.001°		
FEED	Travel (X/Z/ZB)	mm(in)	220/460 (8.7"/18.1")	220/400 (8.7"/15.7")	220/560 (8.7"/22")		220/560/590 (8.7"/22"/23.2")
	Rapid Traverse Rate (X/Z/ZB)	m/min(ipm)	36/36 (1,417/1,417)				36/36/30 (1,417/1,417/1,181)
	Slide Type	-	X-Axis : BALL TYPE LM GUIDE, Z-Axis : ROLLER TYPE LM GUIDE				
TURRET	No. of Tools	EA	12	12 [24]	12	12 [24]	
	Tool Size	OD	mm(in)		□25 (1")		
		ID	mm(in)		Ø40 (1.6")		
	Indexing Time	sec/step	0.2				
LIVE TOOL	Motor (Max/Cont.)	kW(HP)	-	3.7/2.2 (5/3)	-	3.7/2.2 (5/3)	
	Milling Tool Speed (rpm)	r/min	-	5,000	-	5,000	
	Torque (Max/Cont.)	N·m(lbf·ft)	-	23.5/14.2 (17.3/10.5)	-	23.5/14.2 (17.3/10.5)	
	Collet Size	mm(in)	-	Ø16 (0.6") ER25	-	Ø16 (0.6") ER25	
	Type	-	-	BMT55P	-	BMT55P	
TAIL STOCK	Taper	-	MT4				-
	Quill Dia.	mm(in)	Ø56 (2.2")				-
	Quill Travel	mm(in)	-				
	Travel	mm(in)	400 (15.7")		600 (23.6")		-
TANK CAPACITY	Coolant Tank *1)	ℓ (gal)	150 (39.6) {20 Bar : 200 (52.8)}		270 (71.3)		
	Lubricating Tank	ℓ (gal)	1.8 (0.5)				
POWER SUPPLY	Electric Power Supply	kVA	19	22	19	22	24
	Thickness of Power Cable	Sq	Over 16	Over 25	Over 16	Over 25	
	Voltage	V/Hz	220/60 (200/50**2)				
MACHINE	Floor Space (L×W)	mm(in)	2,720×1,685 (107.1"×66.3")		3,392×1,685 (133.5"×66.3")		
	Height	mm(in)	1,862 (73.3")				
	Weight	kg(lb)	4,300 (9,480)		4,500 (9,921)		4,700 (10,362)
PC	Controller	-	HYUNDAI WIA FANUC i Series [SIEMENS 828D]				

*1) Please refer option table if you choose rear direction chip conveyor.

*2) Using 50Hz voltage instead of 60Hz may lower the output of motors. (excluding servo motors and inverter motors)

Specifications are subject to change without notice for improvement.

SPECIFICATIONS

Specifications

[] : Option

ITEM			L230A	L230MA	L230LA	L230LMA	L230LMSA	
CAPACITY	Swing Over the Bed	mm(in)	Ø600 (23.6")					
	Swing Over the Carriage	mm(in)	Ø355 (14")					
	Max. Turning Dia.	mm(in)	Ø355 (14")	Ø310 (12.2")	Ø355 (14")	Ø310 (12.2")		
	Max. Turning Length	mm(in)	440 (17.3")	360 (14.2")	560 (22")	521 (20.5")		
	Bar Capacity	Main	mm(in)	Ø65 (2.6")				
Sub		mm(in)	-				Ø43 (1.7")	
SPINDLE	Chuck Size	Main	8"					
		Sub	-				6"	
	Spindle Bore	Main	Ø78 (3.1")					
		Sub	-				Ø53 (2.1")	
	Spindle Speed (rpm)	Main	4,000 [4,000]					
		Sub	-				5,000 [5,000]	
	Motor (Max/Cont.)	Main	15/11 (20.1/14.7) [22/18.5 (29.5/24.8)]					
		Sub	-				5.5/3.7 (7.4/5) [5.9/4.9 (7.9/6.6)]	
	Torque (Max/Cont.)	Main	286.4/210 (211.2/154.8) [252/211.9 (185.8/156.2)]					
		Sub	-				47.2/31.8 (34.8/23.5) [38/31.6 (28/23.3)]	
	Spindle Type	Main	BELT					
		Sub	-				BELT	
	Spindle Nose	Main	A2-6					
Sub		-				A2-5		
C-axis Indexing	deg	-	0.001°	-	0.001°			
FEED	Travel (X/Z/ZB)	mm(in)	220/440 (8.7"/17.3")	220/400 (8.7"/15.7")	220/560 (8.7"/22")		220/560/590 (8.7"/22"/23.2")	
	Rapid Traverse Rate (X/Z/ZB)	m/min(ipm)	36/36 (1,417/1,417)					36/36/30 (1,417/1,417/1,181)
	Slide Type	-	X-Axis : BALL TYPE LM GUIDE, Z-Axis : ROLLER TYPE LM GUIDE					
TURRET	No. of Tools	EA	12	12 [24]	12	12 [24]		
	Tool Size	OD	□ 25 (1")					
		ID	Ø40 (1.6")					
	Indexing Time	sec/step	0.2					
LIVE TOOL	Motor (Max/Cont.)	kW(HP)	-	3.7/2.2 (5/3)	-	3.7/2.2 (5/3)		
	Milling Tool Speed (rpm)	r/min	-	5,000	-	5,000		
	Torque (Max/Cont.)	N·m(lbf·ft)	-	23.5/14.2 (17.3/10.5)	-	23.5/14.2 (17.3/10.5)		
	Collet Size	mm(in)	-	Ø16 (0.6") ER25	-	Ø16 (0.6") ER25		
	Type	-	-	BMT55P	-	BMT55P		
TAIL STOCK	Taper	-	MT4				-	
	Quill Dia.	mm(in)	Ø56 (2.2")					
	Quill Travel	mm(in)	-					
	Travel	mm(in)	400 (15.7")		600 (23.6")		-	
TANK CAPACITY	Coolant Tank*1)	ℓ (gal)	150 (39.6) {20 Bar : 200 (52.8)}			270 (71.3)		
	Lubricating Tank	ℓ (gal)	1.8 (0.5)					
POWER SUPPLY	Electric Power Supply	kVA	22	25	22	25	27	
	Thickness of Power Cable	Sq	Over 16	Over 25	Over 16	Over 25		
	Voltage	V/Hz	220/60 (200/50*2)					
MACHINE	Floor Space (L×W)	mm(in)	2,760×1,685 (108.7"×66.3")			3,392×1,685 (133.5"×66.3")		
	Height	mm(in)	1,862 (73.3")					
	Weight	kg(lb)	4,400 (9,700)		4,600 (10,141)		4,800 (10,582)	
PC	Controller	-	HYUNDAI WIA FANUC i Series [SIEMENS 828D]					

*1) Please refer option table if you choose rear direction chip conveyor.

*2) Using 50Hz voltage instead of 60Hz may lower the output of motors. (excluding servo motors and inverter motors)

Specifications are subject to change without notice for improvement.

SPECIFICATIONS

Specifications

[] : Option

ITEM			L230C	L230MC	
CAPACITY	Swing Over the Bed		Ø600 (23.6")		
	Swing Over the Carriage		Ø355 (14")		
	Max. Turning Dia.		Ø355 (14")	Ø310 (12.2")	
	Max. Turning Length		422 (16.6")	342 (13.5")	
	Bar Capacity	Main	mm(in)	Ø80 (3.1")	
Sub		mm(in)	-		
SPINDLE	Chuck Size	Main	10"		
		Sub	-		
	Spindle Bore	Main	Ø95 (3.7")		
		Sub	-		
	Spindle Speed (rpm)	Main	3,000		
		Sub	-		
	Motor (Max/Cont.)	Main	18.5/15 (24.8/20.1)		
		Sub	-		
	Torque (Max/Cont.)	Main	460.7/373.5 (339.8/275.5)		
		Sub	-		
	Spindle Type	Main	BELT		
		Sub	-		
Spindle Nose	Main	A2-8			
	Sub	-			
C-axis Indexing		deg	-	0.001°	
FEED	Travel (X/Z/ZB)		220/440 (8.7"/17.3")	220/400 (8.7"/15.7")	
	Rapid Traverse Rate (X/Z/ZB)		36/36 (1,417/1,417)		
	Slide Type		X-Axis : BALL TYPE LM GUIDE, Z-Axis : ROLLER TYPE LM GUIDE		
TURRET	No. of Tools		EA 12		
	Tool Size	OD	mm(in) □ 25 (1")		
		ID	mm(in) Ø40 (1.6")		
	Indexing Time		sec/step	0.2	
LIVE TOOL	Motor (Max/Cont.)		kW(HP)	-	3.7/2.2 (5/3)
	Milling Tool Speed (rpm)		r/min	-	5,000
	Torque (Max/Cont.)		N·m(lbf·ft)	-	23.5/14.2 (17.3/10.5)
	Collet Size		mm(in)	-	Ø16 (0.6") ER25
	Type		-	-	BMT55P
TAIL STOCK	Taper		-		MT4
	Quill Dia.		mm(in)	Ø56 (2.2")	
	Quill Travel		mm(in)	-	
	Travel		mm(in)	400 (15.7")	
TANK CAPACITY	Coolant Tank*1		ℓ (gal)	150 (39.6) {20 Bar : 200 (52.8)}	
	Lubricating Tank		ℓ (gal)	1.8 (0.5)	
POWER SUPPLY	Electric Power Supply		kVA	24	27
	Thickness of Power Cable		Sq	Over 16	Over 25
	Voltage		V/Hz	220/60 (200/50*2)	
MACHINE	Floor Space (L×W)		mm(in)	2,900×1,685 (114.2"×66.3")	
	Height		mm(in)	1,862 (73.3")	
	Weight		kg(lb)	4,500 (9,921)	
PC	Controller		-	HYUNDAI WIA FANUC i Series	

*1) Please refer option table if you choose rear direction chip conveyor.

*2) Using 50Hz voltage instead of 60Hz may lower the output of motors. (excluding servo motors and inverter motors)

Specifications are subject to change without notice for improvement.

CONTROLLER

SIEMENS 828D (L160A Series | L230A Series)

Control function	
Max. configuration of axis	3 axis(MS / SY exception) 4 axis(MS / SY machine only)
Max. configuration of axis and sp.	6 axis(MS / SY exception) 8 axis(MS / SY machine only)
Least Command/input	0.0001mm / 0.00001inch
Feed function	
Feedrate Override	0 - 120%
Rapid Traverse Override	F1, 5, 25/50, 100%
Acceleration with jerk limitation	
Programmable acceleration	
Follow-up mode	
Measuring system 1 and 2, selectable	
Separate path feed for corners and chamfers	
Travel to fixed stop	
Spindle function	
Spindle Override	50% - 120%
Spindle Orientation	
Spindle Speed Limitation	
Rigid Tapping	
Interpolation function	
Linear interpolation axis	Max. 4 axis
Circle via center point and end point	
Circle via interpolation point	
Helical interpolation	
Universal interpolator NURBS (non-uniform rational B splines)	
Continuous-path mode with programmable rounding clearance	
Tool function	
Tool Radius Comp.	
Zero Offset (G54, G55, G56, G57, G58, G59)	100 EA
Programmable Zero Offset	
Tool management	
Display	
CRT / MDI	10.4" Color LCD
SCREEN SAVER	
Manual Operation	
Manual Handle/Jog Feed	
Reposition	
Reference Approach	Ref 1, 2 Approach
Spindle Control	Start, Stop, Rev, Jog, Ort.
Auto Operation	
Single Block	
Feed Hold	
Optional Block Skip	
Machine Lock	
Dry Run	
Simulation	(2 dimensional)
Diagnosis function	
Alarm Display	
Spindle Load Meter/RPM Meter (monitor)	
PLC status/LAD display	

Program function	
Part Program Storage Length	3MB (MS / SY exception) PPU26x.x 5MB (MS / SY machine only) PPU28x.x
Program Name	23 digit
Subroutine Call	(7 level)
Absolute/Incremental Command	G90 - G91
Scaling, ROT	
Inch / Metric Conversion	
Conversational Cycle Program	(22 Machine)
Block Search	
Variable Program (Macro)	
Read / Write System Variable	
BackGround Editing	
Miscellaneous Functions	M - Code
Label Skip	
Program Stop/End	M00, M01, M02, M30
Lookahead, Jerk LimitationFeed & forward control	
ISO Dialect Interpreter(G291) (Fanuc Program exe)	
Maximum number of tools/cuttings	128/256 (MS / SY exception) PPU26x.x 256/512 (MS / SY machine only) PPU28x.x
Number of levels for skip blocks 1	
Protection Function	
Emergency Stop	
Over Travel	Soft Limit & Hard O.T
Contour Monitoring	
Program Protection	
Automation Support Fun.	
Actual Speed Display(Monitor)	
Tool Life Management	(Time, Parts)
Work Count Function	(Internal)
Language Function	
	(6EA) Chinese Traditional, Czech, Danish, Dutch, Finnish, Hungarian, Japanese, Korean, Polish, Russian, Swedish, Portuguese, Turkish
Two Language Switchable	
Data Transfer	
RS 232C I/F / Ethernet	
USB Memory Stick & CF Card	
Option	
Shop Turn	
3D Simulation	
DRF offset	
Teach -in	
Number of levels for skip blocks 8	
TRACYL (Cylinder interpolation)	
TRANSMIT (Pole coordinate command)	
Sister Tool	
A,B,C SPLINE INTERPOLATION	
RCS HOST (Remote Control)	
Simultaneous Recording (Real time monitoring)	
Analysis of Internal Drive Values	
Network Drive Management	

Figures in inch are converted from metric values.

The SIEMENS controller specifications are subject to change based on the policy of company CNC supplying.

CONTROLLER

HYUNDAI WIA FANUC i Series

Control function / Screen display	
Control axis number	Max. 4 Axis X, Z axis X, Z, C axis (M type machine) X, Z, Y, C axis (Y type machine) X, Z, B, C axis (MS type machine)
Simultaneous control axis number	2axes / Linear and circular (Max. 4axes)
Min. input unit	X, Z, Y, B axis : 0.001mm (0.0001") C axis : 0.001 deg.
Min. increment	X, Z, Y, B axis : 0.001mm (0.0001") C axis : 0.001 deg.
High speed HRV control	
Inch/metric conversion	G20 / G21
Interlock	Each axis / All axis
Machinelock	Full axis
Emergency stop	
Stroke check 1	Over-travel
Stroke check 2	
Stroke check 3	
Follow up	
Sub off	
Backlash compensation	+/- 0~9999 Pulse (Rapid traverse & cutting feed)
Position switch	
Fault load detection	Back spin torque limiter (BST)
High resolution transfer control (HRM)	
LCD / MDI	8.4" Color LCD
Operation	
Auto handling (memory)	
MDI handling	
Search function	Sequence, Program
Program re-start	
Preventive function for mis-handling	
Buffer registration	
Program check function	Dry run, Program check
Single block	
Feed function	
Manual jog feed	Rapid transfer, Jog, Handle
Manual Handle Scale	x1, x10, x100
Feed command	Direct command for F code feed
Feed override	0~200% (10% units)
Jog override	0~2,000 mm/min [79 ipm]
Rapid transfer override	F1, F5, F25 / F50, F100%
Override release	
Transfer/minute, transfer/rpm	
Program input and interpolation function	
Nano interpolation	Positioning/Straight/Arc (G00/G01/G02/G03)
Dwell function	G04, 0~9999.9999 sec
Threading retract	
Variable lead threading	
Return of first zero point	G28, manual
Decimal number entering	
Plain selection	G17, G18, G19
Work coordinate selection	G52 to G59
Manual absolute	"ON" fixed
Drawing dimension direct input programming	Included chamfering / Corner R
G code system	A/B/C
Programmable data input	G10
Sub program call	10 folds nested
Custom macro B	
Custom macro variable addition	#100 to #199, #500 to #999
Multiple repetitive cycles	
Multiple repetitive cycles II	
Lathe fixed cycle	

Sub / Main spindle function	
M-Code function	M4 digit number
M-Code function lock	
Lock sp. speed command	S + 4 digit number, binary number output
Main sp. constant control	G96, G97
Spindle speed override	50% ~ 150% (10% unit)
Spindle position decision	
Rigid tapping	
Tool function / Tool compensation	
Tool function	T2 + 2
Tool offset quantity	64 pairs
Tool offset	
Tool nose radius compensation	G40, G41, G42
Configuration/wear compensation	
Direct input of measuring tool compensation B	
Tool life management	
Data input, output and editing function	
Input/output interface	RS232C
Memory card input and output	
Program storing capacity	1280m/512kb
Program registration quantity	Max. 500 programs
Memory lock	
Background edit	
Additional expandable edit	NC program copy, move, change
Screen, diagnosis and setting function	
Self diagnosis function	
Historic screen	Alarm and handling screen
Help function	
Outside message	
Operation time/counter display	
Actual sp. speed, T code display	
Actual machining feed rate display	
Handling monitor screen	Rod meter light
Graphic screen	
Spindle/servo setting screen	
Selection of random 5 EA	
LCD screen save	Screen saver
Auto data backup	
Function according with machine specification	
Cs contouring control	Turn mill
Stored pitch error compensation	Turn mill
Polar coordinate interpolation	Turn mill
Cylindrical interpolation	Turn mill
Canned cycles for drilling	Turn mill
spindle orientation expansion	Turn mill, Sub spindle
Spindle synchronous control	Sub spindle
Torque control	Sub spindle
Y axis offset	Y type machine
Angular axis control	Y type machine
Option	
High speed ethernet	100 Mbps (Option board is required)
Optional block skip	9 ea
3rd & 4th reference point return	
Data Server	1GB
Polygon turning	
Helical interpolation	
Dynamic graphic display	
Protection of data at 8 levels	
Manual guide i	Conversational Programming (10.4" Color LCD)

Figures in inch are converted from metric values.

The FANUC controller specifications are subject to change based on the policy of company CNC supplying.

GLOBAL NETWORK

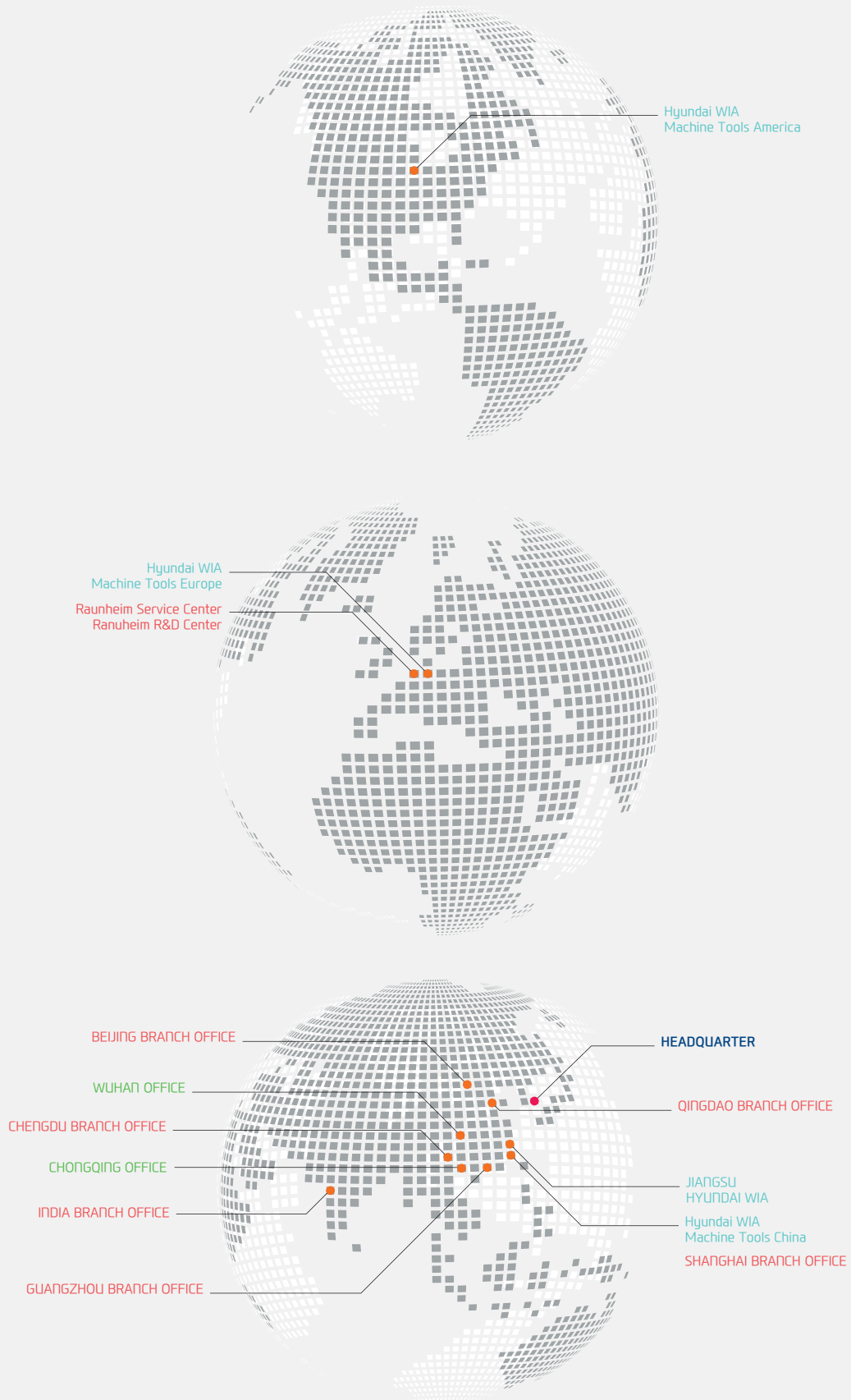

GLOBAL NETWORK



HEADQUARTER

Changwon Technical Center / R&D Center / Factory

153, Jeongdong-ro, Seongsan-gu, Changwon-si,
Gyeongsangnam-do, Korea (Zip Code : 51533)
TEL : +82 55 280 9114 FAX : +82 55 282 9680

Uiwang Technical Center / R&D Center

37, Cheoldobangmulgwan-ro, Uiwang-si, Gyeonggi-do,
Korea (Zip Code : 16082)
TEL : +82 31 596 8209 Fax : +82 55 210 9804

OVERSEAS OFFICES

HYUNDAI WIA Machine Tools America

265, Spring Lake Drive, Itasca, IL, 60143
TEL : +1 630 625 5600
FAX : +1 630 625 4733

Jiangsu HYUNDAI WIA

Company No.6 Fenghuang Road,
Fenghuang Town, Zhangjijagang City,
Jiangsu province, China
TEL : +86 512 5672 6808
FAX : +86 512 5671 6960

Chengdu Branch Office

NO.508 Room, B Block, AFC Plaza, NO.88
Jiaozi Road, High-tech Zone, Chengdu,
China
TEL : +86 028 8665 2985
FAX : +86 028 8665 2985

HYUNDAI WIA Machine Tools Europe

Kaiserleipromenade 5, 63067 Offenbach,
Germany
TEL : +49 69271 472 701
FAX : +49 69271 472 719

Hyundai WIA Machine Tools China Shanghai Branch Office

1-3F, Bldg6, No.1535 Hongmei Road,
Xuhui District, Shanghai, China
TEL : +86 021 6427 9885
FAX : +86 021 6427 9890

Qingdao Branch Office

Room 1207, Cai Fu Building, 182-6 Haier
Middle Road, Qingdao, China
TEL : +86 532 8667 9334
FAX : +86 532 8667 9338

Raunheim Service Center Raunheim R&D Center

Frankfurter. 63, 65479 Raunheim,
Germany
TEL : +49 6142 9256 111
FAX : +49 6142 9256 100

Beijing Branch Office

Floor 14, Zhonghangji Plaza B, No.15
Ronghua South Road, BDA Dist., Daxing
Dist., Beijing, China 100176
TEL : +86 010 8453 9850
FAX : +86 010 8453 9853

Wuhan Office

306-2, A Tower, Jiayu Gpmggian, No12
Chuangye Road, Economic Development
Zone, Wuhan, Hubei, China
TEL : +86 027 5952 3256
FAX : +86 027 5952 3256

India Branch Office

#4/169, Rajiv Gandhi Salai, (OMR),
Kandanchavadi, Chennai-600 096,
Tamilnadu, India
TEL: +91-44-3290-1719

Guangzhou Branch Office

Room 311, Unit 1-3, POLY TAL TU WUP,
Hanxi Avenue, Panyu District, Guangzhou,
China
TEL : +86 020 8550 6595
FAX : +86 020 8550 6597

Chongqing Office

Room 951, #3, Jinrongcheng T3, Jiangbei,
Chongqing, China
TEL : +86 23 6701 2970



L160MA Movie



L160LMSA Movie

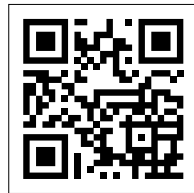

L230A Movie

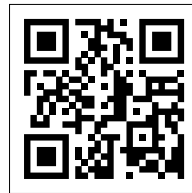

L230LMSA Movie

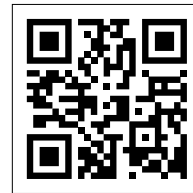

L230LMSA 3D Movie



<http://machine.hyundai-wia.com>

Head Office & Factory

153, Jeongdong-ro, Seongsan-gu, Changwon-si, Gyeongsangnam-do **Tel** +82 55 280 9500

Overseas Sales Team

16F, 37, Cheoldobangmulgwan-ro, Uiwang-si, Gyeonggi-do **Tel** +82 31 593 8173

HYUNDAI WIA Machine Tools America

265 Spring Lake Drive, Itasca, IL, 60143 **Tel** +1 (630) 625 5600 **Fax** +1 (630) 625 4733

HYUNDAI WIA Machine Tools Europe

Kaiserleipromenade 5, D-63067 Offenbach, Germany **Tel** +49 69271 472 701 **Fax** +49 69271 472 719

India Branch Office

#4/169, Rajiv Gandhi Salai, (OMR), Kandanchavadi, Chennai-600 096, Tamilnadu, India **Tel** +91 44 3290 1719